

# **PULSAFEEDER®**

A Unit of IDEX Corporation

## **MPC VECTOR**

**Automatic Flow Control for Chemical Feed Pumps**

### Installation, Operation & Maintenance Manual

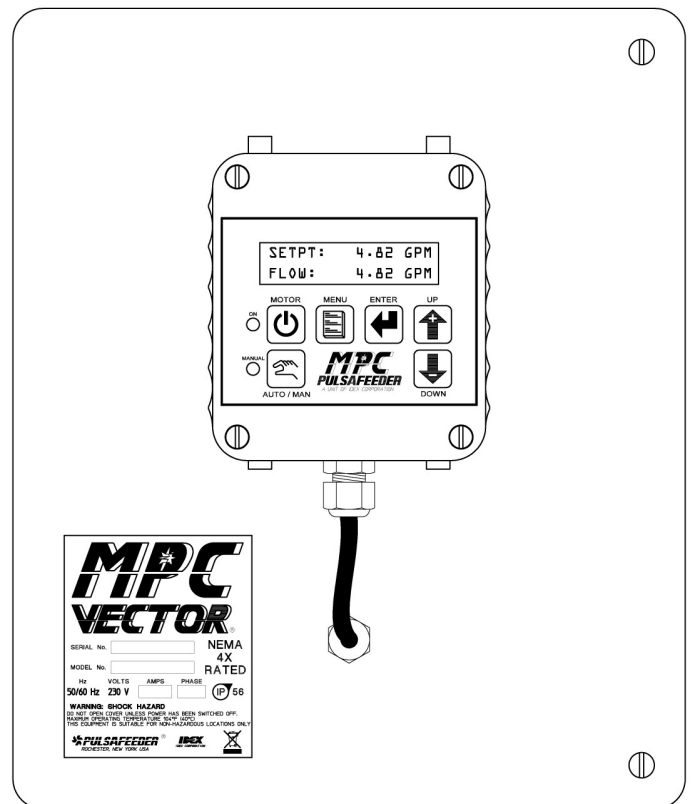

BULLETIN No. IOM-MPCV-0206 Rv. J



Manufacturers of Quality Pumps,  
Controls and Systems

Engineered Pump Operations  
2883 Brighton-Henrietta Townline Road  
Rochester, New York 14623  
Telephone: (585) 292-8000 Fax: (585) 424-5619  
<http://www.pulsa.com> [pulsa@idexcorp.com](mailto:pulsa@idexcorp.com)

# MPC VECTOR™ FACTORY SERVICE POLICY

Your MPC VECTOR is a state of the art microprocessor based motor speed control for use with Pulsafeeder Eclipse Non-Metallic Gear Pumps. It includes extensive on-board diagnostics. If you are experiencing a problem with your MPC VECTOR, first review the on-screen information, then consult the troubleshooting guide. If the problem is not covered or cannot be solved, please contact your local authorized Sales Representative or our Technical Service Department at (585) 292-8000 for further assistance.

Trained individuals are available to diagnose your problem and arrange a solution. Solutions may include purchasing a replacement unit or returning the unit to the factory for inspection and repair. All returns require a Return Material Authorization (R.M.A.) number to be issued by Pulsafeeder. Replacements purchased under a possible warranty situation may be credited after an examination of the original parts by Pulsafeeder personnel.

Certain components may be purchased for replacement. Refer to *Section 19 – Spare Parts* for more information and part numbers. Parts purchased to correct a warranty issue may be credited after examination of the original parts by Pulsafeeder personnel. Parts returned for warranty consideration that test satisfactorily, will be sent back to the originator via freight collect.

**Any field modifications will void the Pulsafeeder warranty. Out-of-warranty repairs will be subject to Pulsafeeder's standard bench fees and testing costs associated with replacement components.**

## FCC Warning

This equipment generates and uses radio frequency energy. If not installed and used properly, in strict accordance with the manufacturer's instructions, it may cause interference to radio communications. Operation of this equipment in a residential area is likely to cause interference, in which case the user, at his own expense, will be required to take whatever measures are necessary to correct the interference.

## Copyright

Copyright © 2006, 2007, 2008 Pulsafeeder, Inc. All rights reserved.

Information in this document is subject to change without notice. No part of this publication may be reproduced, stored in a retrieval system or transmitted in any form or any means electronic or mechanical, including photocopying and recording for any purpose other than the purchaser's personal use without the written permission of Pulsafeeder.

# Table of Contents

1. INTRODUCTION.....	1
1.1 Description .....	1
1.2 MPC VECTOR Standard Features .....	2
2. SAFETY CONSIDERATIONS.....	3
2.1 General Safety.....	3
2.2 Electrical Safety .....	3
2.3 Mechanical Safety.....	3
2.4 Hydraulic Safety.....	3
3. EQUIPMENT INSPECTION.....	4
4. STORAGE INSTRUCTIONS.....	4
4.1 Short Term (0 - 12 months).....	4
4.2 Long Term (12 months or more) .....	4
5. INSTALLATION AND WIRING .....	5
5.1 Location.....	5
5.2 Installation Notes.....	6
5.3 Electrical Wiring.....	6
5.3.1 Controller Layout.....	6
5.3.2 Power Wiring Information .....	8
5.3.3 Power Wiring Diagram .....	9
5.3.4 Input/Output Signal Wiring .....	10
5.4 Check Wiring and Close Access Cover.....	11
5.5 Confirm Correct Incoming Power .....	11
6. START UP AND OPERATION .....	12
6.1 Overview .....	12
6.2 Critical Parameters .....	12
6.3 Keypad/Lamp Operation .....	13
6.4 Confirm Display and Keypad Functionality .....	13
6.5 Motor Parameter Setup .....	14
6.6 Setting Max Flow and Max Speed .....	14
6.7 Flow Display.....	16
6.8 Wrapping up.....	16
6.9 Factory Re-Initialization .....	17
7. INPUT/OUTPUT SETUP.....	18
7.1 Analog Input Setup.....	18
7.1.1 Analog Input 1 – Setpoint .....	18
7.1.2 Analog Input 2 – Flowmeter Feedback .....	18
7.2 Digital Input Setup.....	18
7.2.1 Multi-purpose Digital Inputs .....	18
7.3 Analog Output Setup.....	19
7.4 Digital Output Setup.....	19
8. CALIBRATIONS.....	20
8.1 Pump Flow Calibration.....	20
8.1.1 WET Flow Calibration.....	20
8.1.2 DRY Flow Calibration .....	22
8.2 Analog Input Calibration .....	24

8.2.1	“WET” Analog Input Calibration (with a field signal)	24
8.2.2	“DRY” Analog Input Calibration (keypad only, no signal present)	26
8.3	Analog Output Calibration	28
8.4	PulsaGuard Pump Protection	30
8.4.1	PulsaGuard Calibrations, using Flow Meter Feedback	30
8.4.2	PulsaGuard Calibrations, no Flow Meter Feedback	31
8.5	Display Contrast Adjustment	32
8.6	Tuning the Control Algorithm	33
9.	FLOW METER INPUT	36
9.1	Flow Meter Installation	36
10.	MOTOR PARAMETER SETUP AND TUNING	38
11.	ALARM AND ERROR MESSAGES	41
11.1	Error Log	41
11.1.1	Viewing the Error Log	41
11.1.2	Clearing Error Log Entries	42
11.2	Error Messages	42
12.	SPECIFICATIONS	44
13.	MODEL IDENTIFICATION	47
14.	MENU MAPS	48
15.	FACTORY DEFAULT VALUES	51
16.	RETRIEVAL OF SETUP INFORMATION	51
17.	SPECIAL KEY PRESS ACCESS	51
18.	TROUBLESHOOTING GUIDE	52
19.	SPARE PARTS	53
20.	APPENDIX 1, HANDHELD WIRING	54
20.1	Removal and Connection of the Cable from the Handheld:	54
20.2	Removal and Connection of the Cable from the Base Unit:	55
21.	APPENDIX 2, PID THEORY AND ADJUSTMENT	58
21.1	PID Controller Theory:	58
21.2	Three Control Components:	60
21.3	PID Basic Summary, what happens when I...	61
21.4	Putting it all together to run the <i>MPC Vector</i>	62
21.5	Troubleshooting	63

# Conventions

For the remainder of this bulletin, the following Conventions are in effect.



**A WARNING DEFINES A CONDITION THAT COULD CAUSE DAMAGE TO BOTH THE EQUIPMENT AND THE PERSONNEL OPERATING IT. PAY CLOSE ATTENTION TO ANY WARNING.**



**Notes are general information meant to make operating the equipment easier.**

## Revision History:

2-2006	Rev A	First Release
3-2006	Rev B	New menu maps
		Digital I/O features added
4-2006	Rev C	Add "Speed Mode Flow Cal" instructions
		Misc. minor updates and changes for spelling, grammar, etc
7-2006	Rev D, E	New illustrations, new dimensional diagram, change to MPC Vector name, added model string, minor text revision, added 3 phase information for low Hp motors.
5-2007	Rev F	Updated signal connections diagram Added hand-held wiring diagram Added PID tutorial information in appendix Added startup and parameter setup information section 6
9-2007	Rev G	Added notes and diagram for digital outputs, section 5.3.4 and 7.4 Corrected steps in Dry Flow Cal for Speed Control section Other minor text changes and additions
1-2008	Rev H	Update to match new software revision, multiple changes (3.01)
3-2008	Rev J	Further updates and corrections for new software version (3.01)

## Safety Considerations:

1. Read and understand all related instructions and documentation before attempting to install or maintain this equipment
2. Observe all special instructions, notes, and cautions.
3. Act with care and exercise good common sense and judgment during all installation, adjustment, and maintenance procedures.
4. Ensure that all safety and work procedures and standards that are applicable to your company and facility are followed during the installation, maintenance, and operation of this equipment.



# 1. Introduction

The MPC VECTOR is a microprocessor based motor speed control device, for use with Pulsafeeder pumps. It has been designed for simplicity, yet still has many advanced features that allow the MPC VECTOR to operate in a wide variety of environments and applications. This product is not just a variable speed drive. It is a state of the art multifunctional controller, which provides functionally no one stand-alone variable speed drive does. What makes this product unique is that it combines functionality of three devices in one:

- Vector type variable speed drive.
- Input output processor (4-20 mA in and out, digital input/output), including PID loop for closed loop flow control.
- Power monitor for detection of run-dry conditions

This instruction manual covers the MPC VECTOR control only. For information and safety precautions specific to the pump or any other accessories, please refer to the appropriate IOM.

## 1.1 Description

The MPC VECTOR is an advanced pump controller that is physically separated from the pump's enclosure. Its purpose is to precisely adjust output flow of a process media by means of pump motor speed control.

The MPC VECTOR is designed for a wide variety of control applications. If delivered with a pump and motor, the device is factory configured. Field configuration may be required in certain installations. Local setup and control is achieved through the keypad and a backlit two-line liquid crystal display. Basic operation is simple with dedicated function keys eliminating the need for a sophisticated menu system. Pump output is displayed as Gallons or Liters per Hour (GPH/LPH), Gallons or Liters per Minute (GPM/LPM), or Revolutions per Minute (RPM).

Digital and analog inputs will support a variety of industry standard signals to offer flexible remote control.

The MPC VECTOR is designed to simplify and automate the calibration of pump flow and analog signals. Flow calibration uses on-screen prompting and automated pump operation to eliminate stopwatches, calculators and human inaccuracies. Analog signal calibration is also accomplished by simple keypad entry. It includes a real-time display of signal level. This eliminates the need for external meters.

The MPC VECTOR will accept, and automatically adjust to, either 60 Hz or 50 Hz input power. No special modifications, settings, or adjustments are required. MPC VECTOR controller can be supplied with a 60 Hz, 50 Hz, or dual rated 50/60 Hz motor. The controller/motor combination allows for 60 Hz rated pump flow (1800 rpm motor speed) even when operating from a 50 Hz input. Users in locations with 50 Hz AC supply do not have to de-rate pump flow with this controller.

Minimum motor speed is limited under all circumstances to 31 rpm. **Please note that in certain applications, the practical minimum speed (to achieve flow and pressure) may be higher than 31 rpm.** This can be dependent on product viscosity and other application-specific variables.

Input Frequency	MPC VECTOR Motor	Max MPC VECTOR Output
60 Hz (USA and similar)	60 Hz (or dual rated)	60 Hz / 1800 rpm
50 Hz (Europe, Asia, etc)	50 Hz or 60 Hz or dual rated	60 Hz / 1800 rpm

The motor used with the MPC VECTOR is a three-phase motor; however the three-phase power is generated internally by the MPC VECTOR itself. Do not be confused by the motor nameplate. Input power to the MPC VECTOR is single-phase or three-phase AC 230 volts (see *Section 12, Specifications* for acceptable voltage range). The nameplate on the side of your MPC VECTOR controller will list the appropriate supply requirements for your controller.

Motor Hp Rating	MPC VECTOR Input Power*	Output to Motor**
1	208/230 VAC 1 or 3 phase	230 VAC 3 phase
2	208/230 VAC 1 or 3 phase	230 VAC 3 phase
3	208/230 VAC 1 or 3 phase	230 VAC 3 phase
5	208/230 VAC 3 phase only	230 VAC 3 phase

\* all input ratings are 50 or 60 Hz

\*\* output to pump motor is always 60 Hz maximum frequency

The AC drive used in the MPC VECTOR maintains tight control over voltage and current supplied to the pump motor. This results in lower motor operating temperatures and less stress on motor windings, resulting in longer motor life and more reliable overall operation. Further motor selection information can be found in *Section 12, Specifications* at the end of this manual.

## 1.2 MPC VECTOR Standard Features

- User keypad and display for ease of operation
- Display pump operation in GPH, LPH, GPM, LPM, or RPM
- One 4-20 mA analog input signal for flow control
- One analog (mA) input for flow feedback control (with an external, user supplied flow metering device which provides an analog signal)
- Sensorless vector motor speed control
- Two configurable digital inputs
- Three configurable digital outputs (transistor type, 40 VDC maximum)
- Analog 4-20 mA feedback output
- NEMA 4X and IP56 ratings (for controller housing)
- 230 Volts, 50 or 60 Hz, single or three phase AC power for 1 through 3 Hp systems
- 230 Volts, 50 or 60 Hz, three phase (only) AC power for 5 Hp systems
- Security code lockout of menus
- Standard configurable pump protection utilizing proprietary PulsaGuard technology

## 2. Safety Considerations

- Read and understand all related instructions and documentation before attempting to install or maintain this equipment
- Observe all special instructions, notes, and cautions.
- Act with care and exercise good common sense and judgment during all installation, adjustment, and maintenance procedures.
- Ensure that all safety rules, work procedures, and standards that are applicable to your company and facility are followed during the installation, maintenance, and operation of this equipment.

### 2.1 General Safety

The MPC VECTOR was designed as a controller for operation solely with the Pulsafeeder Eclipse series of non-metallic gear pumps. Use for any other application is considered unsafe and voids all certification markings and warranties.

### 2.2 Electrical Safety

The MPC VECTOR is an industrial process controller. Improper application and use can be hazardous. You are solely responsible for its use.

The MPC VECTOR electrical installation must conform to all relevant electrical codes. Installation and electrical maintenance must be performed by a qualified electrician. Before installing or servicing this device, all power must be disconnected from the source at the main distribution panel.

The MPC VECTOR emits electro-magnetic energy and may generate radio frequency interference. Its use is restricted to industrial applications. You are responsible for shielding this energy/interference.

Certain wiring procedures may require that the user wear a wrist strap to dissipate static charges.

**Wait a minimum of 5 minutes after disconnecting power before servicing the MPC VECTOR or pump motor. Capacitors retain a charge even after power is removed from the controller.**

### 2.3 Mechanical Safety

Users should note that the pump motor is always under the control of the MPC VECTOR, and as such may actuate without warning. Care should be taken to keep loose clothing and other objects away from the pump motor.

The MPC VECTOR was designed to be service free. It contains no user-maintainable components. Disassemble the MPC VECTOR enclosure only for initial field wiring, or as instructed to do so within this manual. Evidence of unauthorized disassembly shall void the warranty.

### 2.4 Hydraulic Safety

Thoroughly review and adhere to the contents of the pump Installation, Operation, Maintenance and Instruction manual for any pump used with the MPC Vector control. As a microprocessor controlled device, the MPC VECTOR may activate the pump motor without warning – generating hydraulic pressure and fluid flow. Care should be taken to protect both users and systems should the pump activate.

## 3. Equipment Inspection

When you receive your order, check all equipment for:

- Completeness against the shipping document / purchase order
- For any evidence of shipping damage.

Shortages or damage should be reported immediately to the carrier and your Pulsafeeder Representative.

## 4. Storage Instructions

The MPC VECTOR can be successfully stored for extended periods. The key to this success is temperature and humidity control.

### 4.1 Short Term (0 - 12 months)

The MPC VECTOR should be stored in a temperature and humidity controlled environment. It is preferable to keep the temperature constant in the range of -18° to 60° Celsius (0° to 140° Fahrenheit). The relative humidity should be 0 to 90% non-condensing.

### 4.2 Long Term (12 months or more)

Storage of the MPC VECTOR for periods of longer than twelve months is not recommended. If extended storage is unavoidable the MPC VECTOR should be stored in accordance with those conditions stipulated for Short Term Storage. In addition, a porous bag of 85g (3 oz) silica gel or similar desiccant should be placed inside the enclosure. The cover should be re-installed to seal the desiccant within the enclosure. The conduit connections must be tightly capped.



#### Special note for long-term storage:

If AC input power has not been applied to the MPC VECTOR for a period greater than 12 months, the controller must be prepared for operation. The MPC VECTOR should have AC power applied at the input for a period of 8 hours before placing pump into normal operation. Refer to Installation and Wiring section for AC power connection instructions.

# 5. Installation and Wiring

## 5.1 Location



Review the Safety section (*Section 2*) prior to installing the MPC VECTOR. It contains information required to properly install and operate the MPC VECTOR in an industrial environment.

The site selected for the installation of your MPC VECTOR is largely dependent on that of the gear pump. Review the Installation, Operation, and Maintenance manual provided with your gear pump. It details system related issues that are important to proper operation of the pump. Consider the following MPC VECTOR related issues when selecting a site. Avoid locations where the MPC VECTOR would be subjected to extreme cold or heat. Note the warning statement on the next page. The installation of this device must comply with national, state and local codes.

The MPC VECTOR controller must be secured to an appropriate support before use. Use appropriate hardware to secure the MPC VECTOR controller and pump to a smooth vertical surface. No assembly is required for the MPC VECTOR controller itself.

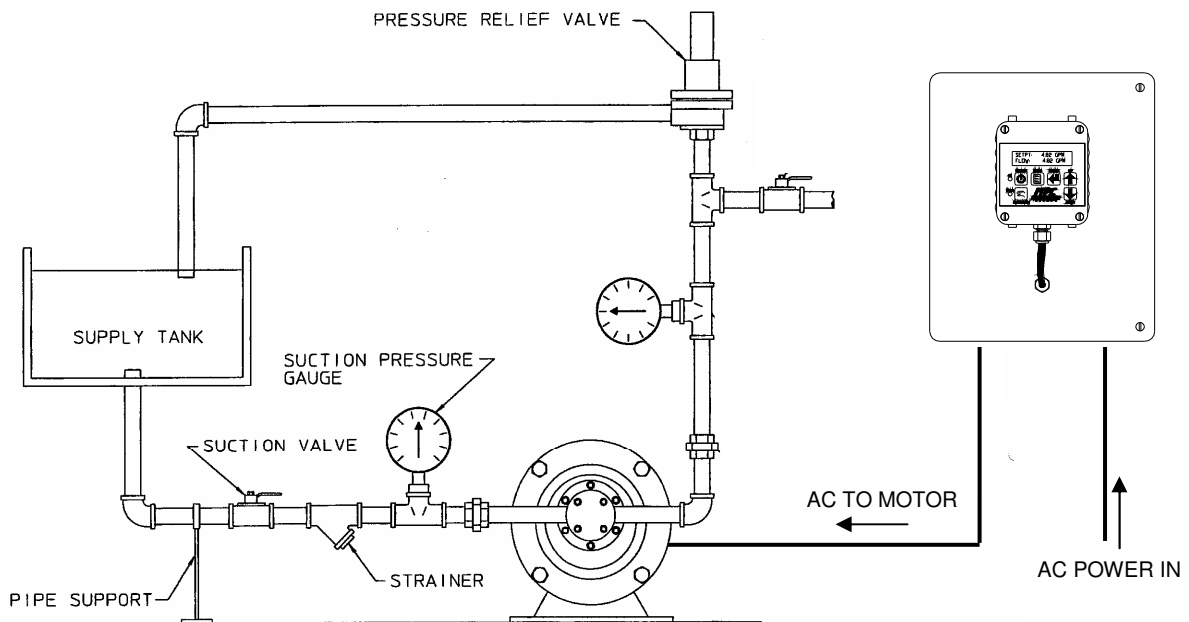

Figure 1 – Typical Installation.



**AVOID LOCATIONS WHERE THE MPC VECTOR WOULD BE SUBJECTED TO EXTREME COLD OR HEAT [LESS THAN 0° CELSIUS (32° FAHRENHEIT) OR GREATER THAN 40 ° CELSIUS (104 ° FAHRENHEIT)] OR DIRECT SUNLIGHT. FAILURE TO OBSERVE THIS WARNING COULD DAMAGE THE MPC VECTOR AND VOID ITS WARRANTY.**

## 5.2 Installation Notes

The MPC VECTOR is a microprocessor-based controller that uses electro-static sensitive CMOS components. Do not make any (high or low voltage) electrical connections without adequately grounding the MPC VECTOR and the worker to eliminate an electro-static charge between the two. **A conductive wrist strap worn by the worker and attached to the MPC VECTOR's internal ground plate is adequate to satisfy this requirement.**

Calibration is an important element of successful MPC VECTOR operation. If a flow meter is being used for process feedback the flow meter must be calibrated prior to MPC VECTOR calibration according to manufacturer recommendations.

Conduit connections can carry fluids and vapors into the MPC VECTOR causing damage and void the warranty. Care should be taken when installing conduit to protect against fluid/vapor entry. If necessary, provide sealed entries or conduit drains near the point of entry. The user must supply the correct connection for the power entry, as per the local codes and requirements. Any cable entrances that are not used should be appropriately sealed against moisture and vapors.

## 5.3 Electrical Wiring

**Wait a minimum of 5 minutes after disconnecting power before servicing the MPC VECTOR or pump motor. Capacitors retain a charge even after power is removed from the controller.**

1. Make the motor connections between the control unit and the pump motor (*ref. Figure 3*).
2. Make the incoming AC power connections and the outgoing power connections to the pump motor (*ref. Section 5.3.2*). These will allow you to operate the MPC VECTOR and attached Eclipse pump.
3. Decide which signal (control) Inputs and Outputs (e.g., 4-20mA in) will be used and make those connections (*ref. Section 5.3.4*).
4. Power-up and test the MPC VECTOR to confirm the connections and check for proper operation.
5. Configure the software via the menu system for the desired operational conditions. Depending on the anticipated function, users may need to enter settings for the following:
  - a. Analog input signal, so the MPC VECTOR can accept a process input signal
  - b. Digital input settings, for example start/stop and/or tank level inputs
  - c. Digital output settings, for example auto/manual status and/or alarm outputs
6. Conduct a final power-up and test the MPC VECTOR to confirm the connections and check for proper operation.
7. Go to the *Section 6 – Start Up and Operation* for details on how to perform the power-up tests.

### 5.3.1 Controller Layout

The design of the MPC VECTOR incorporates all control circuitry onto one easily accessed circuit board. This board is located on the inside of the main controller. Gain access to this board by removing the 2 cover screws allowing the cover to hinge open.

FRONT VIEW: MOUNTING HOLES

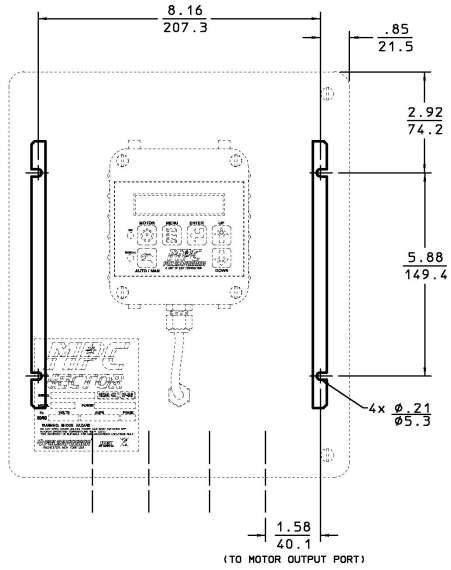

FRONT VIEW, COVER OPEN

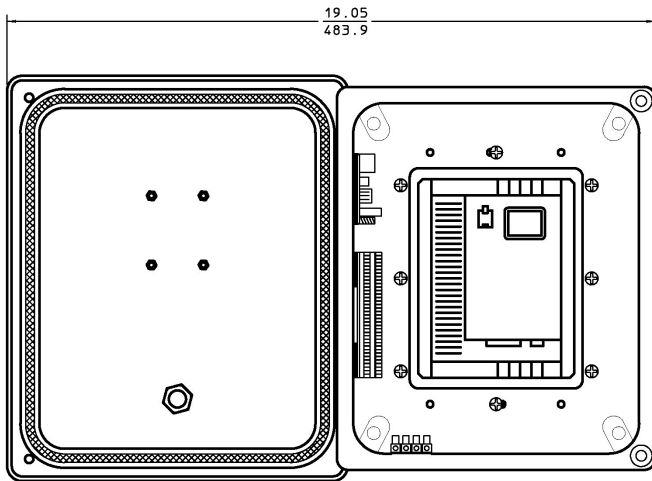

FRONT VIEW

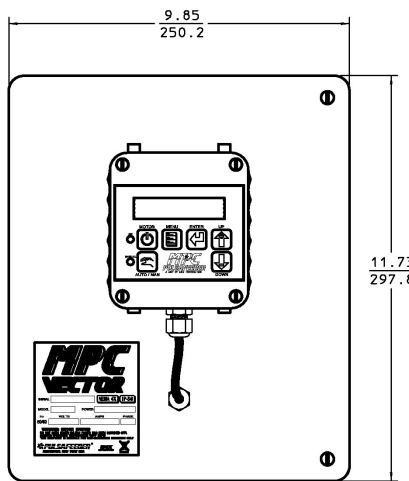

SIDE VIEW

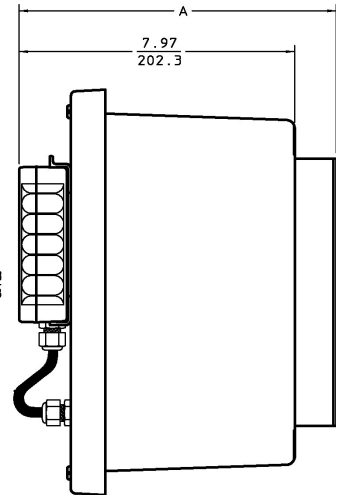

SIZE	DIM	
	A	B
1 HP *	9.50/241.3	4.16/105.7
2 HP *	9.50/241.3	4.16/105.7
3 HP	9.82/249.5	4.47/113.5
5 HP	10.86/275.9	5.51/140.0

NOTES: \* 1 AND 2 HP MODELS COME WITH HEAT SINK ADAPTOR BRACKETS TO MAKE INSTALLATION EASIER - THE DIMENSIONS SHOWN ARE WITH THESE BRACKETS INSTALLED ON THE UNIT.

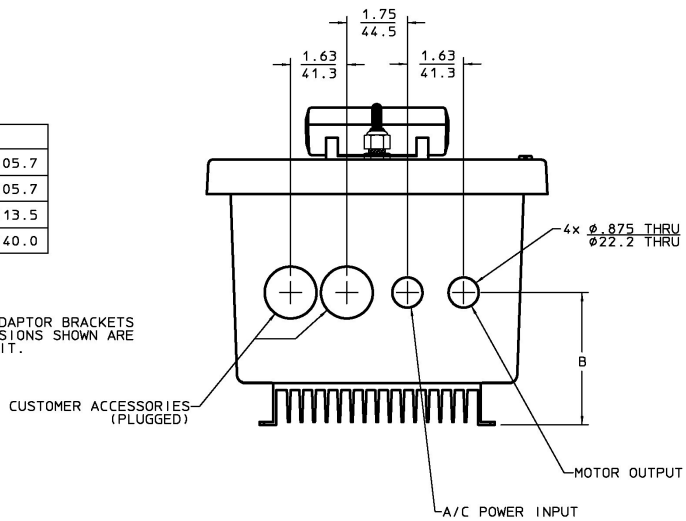

Figure 2 – Controller Layout and Dimensions

### 5.3.2 Power Wiring Information



NOTE

- Verify the correct supply voltage (230VAC single-phase or three-phase) with the nameplate affixed to your MPC VECTOR. Ensure that your supply voltage matches the MPC VECTOR configuration.
- The 1 hp, 2 hp, and 3 hp AC drives use single phase or three phase 230VAC input. The 5 hp AC drive must be powered by three phase 230VAC input only.
- Wires should be routed within the enclosure in a manner that maintains separation between high voltage and low voltage conductors. High voltage conductors should be routed to the side opposite the control circuitry.
- Incoming power wiring should adhere to all applicable local and national electrical codes and regulations. A circuit breaker or fuse must be provided as noted below.
- Upon initial application of AC power, a current inrush will occur to charge the DC bus capacitors. This is normal operation, and breakers and other circuit protection devices should be sized accordingly.

The MPC VECTOR requires one connection to an external power source. It uses this same connection to power its own supply as well as the AC pump motor. You must take all of these loads into consideration when sizing the branch circuit (*see Table 1*). A circuit breaker or disconnect switch with fuses must be wired in series with terminals L1 and L2/N in accordance with all applicable local and national electrical codes and regulations. The circuit breaker or disconnect switch shall be located in close proximity to the MPC VECTOR controller installation, and must be marked or labeled to identify it as the power disconnect for the MPC VECTOR.

Power Requirements	Recommended Minimum Wiring and Circuit Breaker							
	Single Phase 208/230 VAC				Three Phase 208/230 VAC			
	Actual Draw	Circuit Breaker	Wire Size	Wire Size	Actual Draw	Circuit Breaker	Wire Size	Wire Size
MPC VECTOR and 1.0 Hp motor	10.6 A	15 A	14 AWG	2.0 mm <sup>2</sup>	5.8 A	10 A	14 AWG	2.0 mm <sup>2</sup>
MPC VECTOR and 2.0 Hp motor	14.8 A	20 A	14 AWG	2.0 mm <sup>2</sup>	9.1 A	15 A	14 AWG	2.0 mm <sup>2</sup>
MPC VECTOR and 3.0 Hp motor	19.7 A	25 A	12 AWG	3.5 mm <sup>2</sup>	12.4 A	20 A	14 AWG	2.0 mm <sup>2</sup>
MPC VECTOR and 5.0 Hp motor	---	---	---	---	19.6 A	25 A	12 AWG	3.5 mm <sup>2</sup>

Table 1 – Sizing Branch Circuits

The MPC VECTOR controller is provided with a 7/8” thru hole for incoming AC power wiring and a 7/8” thru hole for motor wiring at the bottom of the enclosure. Utilize the appropriate conduit fittings to route and seal the supply wires into the MPC VECTOR enclosure.

The power wires are secured to the terminal strip at the bottom end of the AC drive as per *Table 2*. Remove approximately 0.20 – 0.25” of insulation from the end of each conductor. Loosen the terminal strip screw, and insert the stripped wire end fully into the terminal. Tighten the screw to

secure the conductor, making certain that the terminal grips the wire, not the insulation. Ensure that all wiring meets applicable local and national codes and requirements.

### 5.3.3 Power Wiring Diagram

MPC VECTOR Drive Terminal	Single Phase 208/230 VAC	Three Phase 208/230 VAC
L1	Line 1	Line 1
L2	N/C	Line 2
L3	Line 2	Line 3
Ground Plate	Ground	Ground

Table 2 – AC Drive Terminals

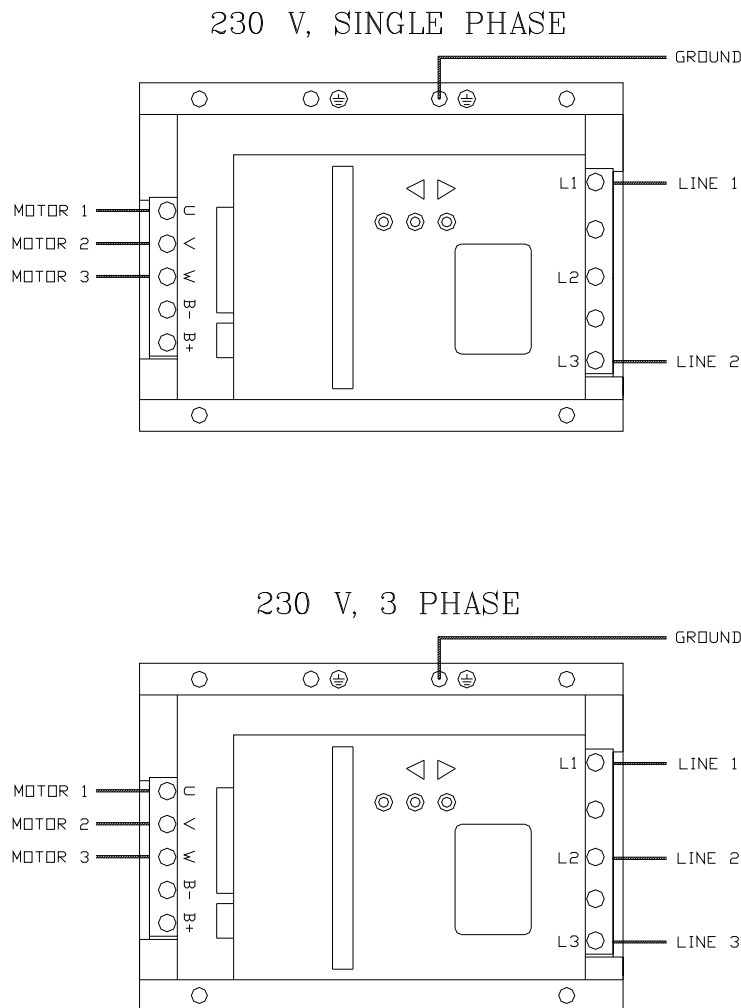



Figure 3 – AC Power Connections

**Wait a minimum of 5 minutes after disconnecting power before servicing the MPC VECTOR or pump motor. Capacitors retain a charge even after power is removed from the controller.**

### 5.3.4 Input/Output Signal Wiring

Signal wiring is routed through the two unused conduit openings at the base of the MPC VECTOR. All input/output signals are connected to the terminal strips at the edge of the MPC VECTOR circuit board except for flow meter feedback which is connected to a separate terminal block. Use caution to observe proper wire location and signal polarity. Always cap or plug unused openings. Wires should be routed within the enclosure in a manner that maintains separation between high voltage and low voltage conductors. Ensure all low voltage wiring is installed as per any applicable local and national electrical codes and regulations.

Utilize 16 to 22 AWG, 250 V shielded cable with a 75°C insulation rating (or better) for all signal input and output wiring. Recommended strip length is 0.39” or 10 mm. Refer to *Figure 4* below for signal connection locations.

 **Unused conduit openings should be plugged as required to avoid ingress of moisture and contaminants into the MPC VECTOR enclosure. Do not remove the factory provided plug from openings that are not required for field wiring.**

 **IT IS RECOMMENDED THAT A WRIST STRAP BE WORN WHEN MAKING CONNECTIONS TO ANY PRINTED CIRCUIT BOARD.**

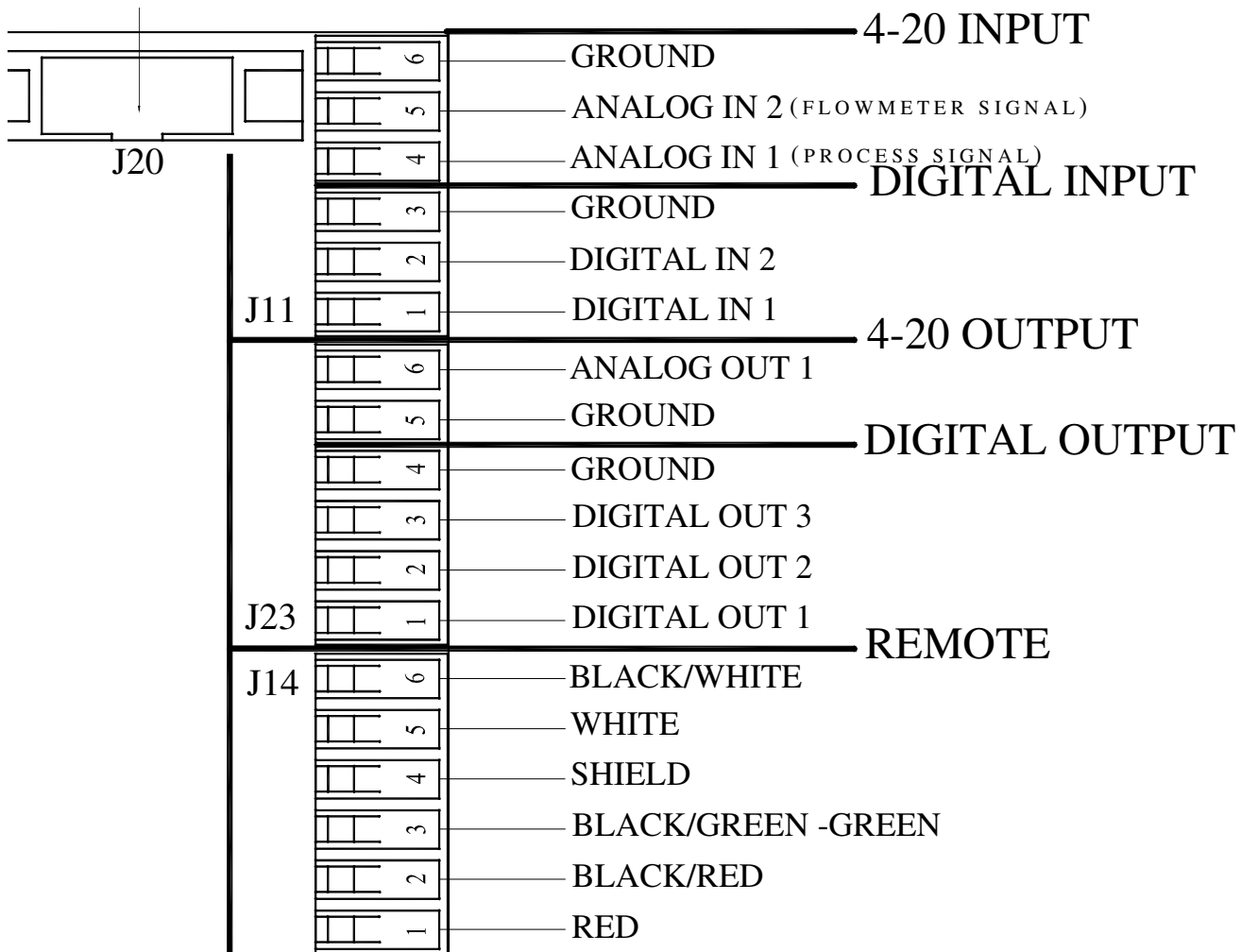

Figure 4a – Signal Connections

Digital output signals can drive devices such as relays or indicator lamps. 5 to 24 VDC power must be supplied from an external source. Each output has a maximum current capability of 500 mA. Maximum voltage capability of these circuits is 40 VDC (see *Section 12, Specifications*, for more information).

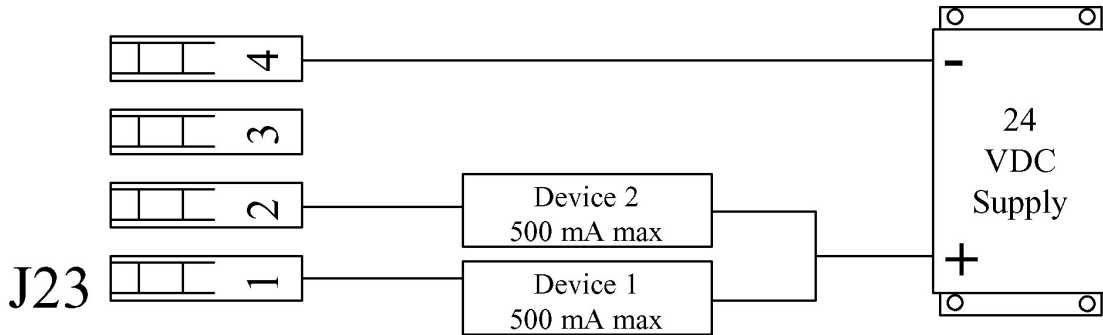

Figure 4b – Sample Digital Output Connections, (power can be in the range of 5 – 24 VDC)

## 5.4 Check Wiring and Close Access Cover

Double-check all of your electrical connections. Pay attention to polarity of all inputs and outputs – both low and high voltage. Additionally, insure that all terminals are clamping onto the bare conductor, not on its insulation. Ensure that wires will not be trapped or pinched when front cover is replaced and secured. Ensure that excess insulation is not removed from the wires, as this can lead to poor connections or faulty operation.

Replace the main access cover and secure the 2 screws.

## 5.5 Confirm Correct Incoming Power



**WITHOUT PRIOR OPERATING KNOWLEDGE, IT IS IMPOSSIBLE TO TELL IF THE PUMP MOTOR WILL RUN WHEN POWER IS APPLIED TO THE MPC VECTOR. YOU ARE RESPONSIBLE FOR TAKING THE NECESSARY STEPS TO ENSURE THAT ALL ASPECTS OF SAFETY HAVE BEEN CONSIDERED (E.G., ELECTRICAL, HYDRAULIC, ETC.).**

Turn on power at the mains or distribution panel. If the MPC VECTOR's incoming power is connected correctly, the backlighting on the MPC VECTOR's display will illuminate (depending on lighting conditions, it may be necessary to shade the display to confirm illumination). If the display is not illuminated, first check the line voltage with a voltmeter. If the voltage is not correct, return to *Section 5.3.2 – Power Wiring Information*. Otherwise, proceed with the next step.

# 6. Start Up and Operation

## 6.1 Overview

Once all electrical connections have been made, your MPC VECTOR is ready for setup and operation. The following sections detail the procedures required to complete the MPC VECTOR start up.



**WHEN POWER IS SUPPLIED TO THE UNIT, LINE VOLTAGE IS PRESENT WITHIN THE MPC VECTOR ENCLOSURE EVEN WHEN THE MOTOR IS OFF.**

**DURING START-UP, IT IS NECESSARY TO RUN THE PUMP MOTOR. THIS WILL CAUSE FLUID TO DISCHARGE FROM THE PUMP. YOU ARE RESPONSIBLE FOR SAFELY DIVERTING FLOW FROM THE PUMP DURING START-UP AND CALIBRATION.**

## 6.2 Critical Parameters

For proper operation of the MPC VECTOR control, at startup the following parameters and calibrations must be entered and/or verified:

<b>Parameter(s)</b>	<b>Reference IOM Section</b>
Pump maximum flow	Section 6.6
Flow meter calibration (if using this feature)	Ref flowmeter IOM as required
Flow calibration in speed mode	Section 8.2
Motor calibration for Vector mode	Section 10
4-20 mA analog signal calibration	Section 8.3
Flow meter type setup	Section 9

## 6.3 Keypad/Lamp Operation









Key	Function	Description
	Motor On/Off	Press to start pump, press again to stop pump
	Auto/Manual	Press to toggle between automatic operation and manual control of the pump
	Menu	Press to adjust controller settings, to exit the menu system, to move cursor back when entering values, or to step back to higher level menus
	Enter	Press to accept changes in menus, to move cursor forwards when entering values, and to access lower level menus.
	Arrow Up	Press to adjust values upwards, and to scroll through menu options
	Arrow Down	Press to adjust values downwards, and to scroll through menu options
Lamp	Color	Description
ON 	Green, Amber, Red, Off	Off = Motor off                      Green = Motor on Amber = Remote standby          Red (blinking) = Error
MANUAL 	Green, Off	Green = Manual Control              Off = Automatic Control

Table 3 – Keypad and Lamp Operation

## 6.4 Confirm Display and Keypad Functionality



The example display messages are shown in English for demonstration purposes. If an alternate language has been set, the text is displayed as a translation of the English version.

Now that you have confirmed that the MPC VECTOR is receiving power, it is necessary to confirm that the display and keypad are functioning properly. On normal power-up, the display appears for approximately 2 seconds.

```
PULSAFEEDER INC.
FW: 00.00/00.00
```

The first four digits displayed are the software revision for the MPC VECTOR control board, and the second four indicate the software revision for the remote board.



The revision numbers should be identical for both units. Unpredictable or unstable operation may result from mismatched software revisions.

Please note that it may be necessary to adjust the display contrast. Please refer to *Section 8.6* if this is required.

## 6.5 Motor Parameter Setup

The MPC VECTOR controller interfaces closely with the Eclipse pump motor. The MPC VECTOR needs to know certain details about the motor in order to function properly. End users may have to input or adjust motor parameters before operation. Use the following as a guide:

**If you:** Have received your MPC VECTOR and Eclipse pump and motor as a unit from the factory,  
**and** Your MPC VECTOR to motor wiring distance is *less than* 25 feet

Then you should not have to perform any parameter setup or calibration. All parameters and setup have been completed for you at the factory.

**If you:** Are using the MPC VECTOR with a motor that did not come from the factory, *or*  
Your MPC VECTOR to motor wiring distance is *greater than* 25 feet, *or*  
You are replacing the motor on an existing setup

Then you may have to enter the motor parameters, and you will have to perform a motor auto-setup procedure. Please reference *Section 10, Motor Parameter Setup and Tuning*, before proceeding with operation of your MPC VECTOR controller.

## 6.6 Setting Max Flow and Max Speed

What is Max Flow?

The value entered into the Max Flow is largely used for display purposes. It limits the flow rates that can be entered during normal operations, as well as during analog calibration routines and PulsaGuard calibration. Internally it is also used in PID calculations.

What should my Max Flow be set to?

Max Flow can vary for a gear pump based on the viscosity of the fluid being pumped and the system pressure. It is recommended that the Max Flow be set 10% higher than your pump is rated for at 0PSI. This will allow for a full range of data entry.

What if I try to set my pump to a flow higher than it can actually achieve for my current pressure and viscosity?

The pump has internal software protections and validations which prevent the motor from exceeding 1800 RPM (approximate). If the pump can only achieve 2.5GPM at 1800 RPM for your system configuration and the flow rate is set to 10GPM, the motor will spin at 1800 RPM and produce 2.5GPM.

What is Max Speed?

Max Speed is the maximum speed that the motor can spin, according to the manufacturer. This is largely unused by the MPC Vector at the moment and will not affect operations. It is recommended that this value is kept at 1800 RPM.

## Setting Max Flow

- 1) Begin at the main screen displaying the current flow/speed setpoint

```
SETPT      0 . 0 0 GPM
FLOW       0 . 0 0 GPM
```

- 2) Press the MENU key to access the menus.

```
- MENU -
CALIBRATION
```

- 3) Press the UP or DOWN arrow keys until you get to System Setup.

```
- MENU -
SYSTEM SETUP
```

- 4) Press the ENTER key to access System Setup Menus.

```
SYSTEM SETUP
STATUS
```

- 5) Press the UP key until you see the Information setup option.

```
SYSTEM SETUP
INFORMATION
```

- 6) Press the ENTER key to access the Information screens.

```
PULSAFEEDER, INC
FW : 1 . 0 4 / 1 . 0 4
```

- 7) Press the UP or DOWN arrow keys until you see Max flow and Speed displayed.

```
MAX :      6 . 0 0 GPM
MAX :      1 8 0 0 RPM
```

- 8) Press the Enter key to allow Max Flow to be edited. A blinking cursor will appear

```
MAX :      6 . 0 0 GPM
MAX :      1 8 0 0 RPM
```

- 9) Press the UP or DOWN arrow keys to manipulate the flow rate until you reach your max flow.

```
MAX :      8 . 5 0 GPM
MAX :      1 8 0 0 RPM
```

- 10) Press the ENTER key to accept the new Max Flow rate. Note that the blinking cursor has moved to the Max Speed location.

```
MAX :      8 . 5 0 GPM
MAX :      1 8 0 0 RPM
```

- 11) Press the ENTER key again to save the Max Flow and Max Speed. Note that the blinking cursor should disappear at this point.

```
MAX :      8 . 5 0 GPM
MAX :      1 8 0 0 RPM
```

## 6.7 Flow Display

The MPC VECTOR will display calibrated pump flow in GPH, LPH, GPM, or LPM on the digital display when configured for flow control. The motor speed (in RPM) may also be viewed while in flow control. Changes to the flow units are made in the *System Setup* Menu.

## 6.8 Wrapping up

Your MPC VECTOR is now commissioned for use. Note that you cannot configure the software in a way that would damage the MPC VECTOR. Typically, whenever you are about to set a critical value (e.g., Calibrate Flow), you are always prompted to confirm your change before it takes effect. If you are ever dissatisfied with the configuration of your MPC VECTOR, you can always return to the Factory Defaults by referring to *Section 6.7*.

## 6.9 Factory Re-Initialization



**Factory Re-initialization is typically not required. When re-initializing your MPC VECTOR, all of the system settings and calibration information will be overwritten by the original factory default settings. The controller must be re-configured and re-calibrated to your specifications.**

A Factory Re-initialization should be performed only if there is reason to believe that the MPC VECTOR is operating abnormally. The condition usually manifests itself with inconsistent or erratic operation – often associated with meaningless characters on the display, or exaggerated numerical values. Commonly, a user has entered incorrect parameters, or made changes to the setup of the control.

Once a re-initialization has been performed, all operating parameters should be checked and adjusted or re-entered as necessary, including maximum flow and rpm, motor parameters, flow and analog signal calibrations, etc.

### Factory Re-Initialization:

1. Press the MENU key to access the System Setup Menu

```
– MENU –  
CALIBRATION
```

2. Press the UP arrow key to display

```
– MENU –  
SYSTEM SETUP
```

3. Press the ENTER key

```
SYSTEM SETUP  
STATUS
```

4. Press the UP arrow key twice

```
SYSTEM SETUP  
FACTORY INIT
```

5. Press the ENTER key

```
PRESS ENTER  
TO FACTORY INIT
```

6. Press the ENTER key

```
ARE YOU SURE?  
YES=ENTER NO=MENU
```

7. Press the ENTER key

```
RESETTING PUMP  
TO FACTORY INIT
```

## 7. Input/Output Setup

Use the “DIGITAL I/O” and “ANALOG I/O” menus to activate the functions required for the intended application.

Users may also reference *Section 14 – Menu Maps* for additional configuration assistance

### 7.1 Analog Input Setup

Two Analog Inputs are provided for the User. Analog Input 1 is used for Setpoint input. Analog Input 2 is used for systems configured for analog process feedback from a flow meter.

#### 7.1.1 Analog Input 1 – Setpoint

See Figure 4 – Signal Connections to insure that you have your Analog Input signal connected to the proper location before activating. Use the “ANALOG I/O” menu to activate the analog input signal function. The menu can be used to set the analog input to either ACTIVE or INACTIVE. The setpoint input should be calibrated prior to activation (*ref. Section 8.2 – Analog Input Calibration*).

#### 7.1.2 Analog Input 2 – Flowmeter Feedback

See *Section 9* Flow Meter Input for installation instructions. The flow meter input signal must be configured properly prior to use. Use the “FLOW SENSOR” sub-menu under “SYSTEM SETUP” to enable the process feedback analog input. The flow sensor type must be set to “ANALOG” to enable this input. The process feedback input should be calibrated prior to activation (*ref. Section 8.1 – Pump Flow Calibration*).

### 7.2 Digital Input Setup

#### 7.2.1 Multi-purpose Digital Inputs

Each of the 2 Digital INPUTS can be selected as:

- Inactive
- Tank Level Input
- Leak Detection (using external device)
- Remote ON/OFF Input
- Flow verification Input

Each can be set as normally OPEN or normally CLOSED. For example, if an input is set to ON/OFF and NORMALLY CLOSED, this means a CLOSED switch will activate the pump. A NORMALLY OPEN setup will give the opposite response. These inputs are to be attached to a dry contact circuit only, apply no voltage to these inputs.

## 7.3 Analog Output Setup

No setup is required for the analog output. Analog output is always available at the corresponding terminals (see wiring diagram Figure 4a, Section 5.3.4). The analog output follows and is proportional to motor speed.

## 7.4 Digital Output Setup

Each of the 3 Digital OUTPUTS can be selected as:

- ON/OFF Status
- AUTO/MAN Status
- Leak Detected
- Alarm Indicator
- Tank Level Status

Each can be set as normally OPEN or normally CLOSED. For example, if an output is set to ON/OFF INDICATION and NORMALLY CLOSED, this means that when the motor is running (indicator lamp is ON) the output will be CLOSED. A NORMALLY OPEN setup will give the opposite response.

Digital output circuits are transistor based and limited to 40 VDC maximum, see *Section 5.3.4, Input/Output Signal Wiring*, and *Section 11, Specifications*, for more information).

# 8. Calibrations

As a convention in this manual:

“**WET**” *calibrations* will refer to those that require normal operating conditions, for example the pump running with fluid, or an electrical signal input provided at the appropriate terminals.

“**DRY**” *calibration* routines are run under other conditions, and often do not require the pump to run or that a specific input signal be present.

Some of the calibration routines may be performed either way. Note any system requirements listed for each routine.

## 8.1 Pump Flow Calibration

Pump flow calibration is not necessary for the standard speed controller. It is only necessary for models configured for flow meter feedback. The selected flow meter should meet or exceed requirements listed in the Flow Meters section (*ref. Section 12 - Specifications*). The flow meter should also be calibrated prior to MPC VECTOR calibration according to manufacturer specifications.



**YOUR MPC VECTOR IS NOT FACTORY CALIBRATED AS THE CALIBRATIONS ARE SYSTEM DEPENDENT AND FLOW METER DEPENDENT. YOU MUST ALWAYS PERFORM A CALIBRATION WITH THE MPC VECTOR INSTALLED IN YOUR SYSTEM PRIOR TO USE. FAILURE TO PROPERLY CALIBRATE THE UNIT MAY RESULT IN DAMAGE TO SYSTEM COMPONENTS.**

The pump may be calibrated in WET (under normal operating conditions) or DRY (performed with pump off) conditions.

### 8.1.1 WET Flow Calibration

The Wet Flow Calibration routine will require that the user turns on the pump. The flow meter should be configured and calibrated prior to MPC VECTOR calibration (*refer to flow meter IOM for calibration instructions*). Please note that it must be safe to run the pump and dispense liquid into the system in order to complete this calibration. The pump should be fully primed with the product in order to complete an accurate calibration.

1. Press the MENU key to access the Calibration Menu.

– MENU –  
CALIBRATION

2. Press the ENTER key to access Pump Flow Calibration screen.

CALIBRATION  
PUMP FLOW

3. Press the ENTER key to access Wet Pump Flow Calibration screen.

PUMP FLOW  
WET CAL

4. Press the ENTER key to begin Flow Calibration

CAL SPEED  
RPM 0

- Using the UP and/or DOWN arrow keys adjust the motor speed to approximate setpoint. This speed is just a reference point for the MPC VECTOR to measure flow meter input. If the maximum motor speed for a given application is known, it is best to use this as a flow calibration point.

```
      CAL SPEED
RPM           1800
```

- Press the ENTER key to accept the calibration speed.

```
      START MOTOR
YES=ENTR NO=MENU
```

- Press the ENTER key to start the motor and advance to the flow entry screen. You cannot start the motor with the motor key during MENU operations.

```
      PUMP FLOW
FLOW : 000.00GPM
```



**THE MOTOR WILL START WHEN THE ENTER KEY IS PRESSED. MAKE SURE THAT YOUR SYSTEM IS PREPARED FOR OPERATIONS BEFORE STARTING THE MOTOR.**

- Obtain flow rate from flow meter.



**Pay close attention to the units used for flow rates. The flow rate entered into the MPC VECTOR calibration MUST match the units displayed on the MPC VECTOR. You may back out of this calibration routine at this time and change the MPC VECTOR flow units, if necessary.**

- Enter the flow rate from your flow meter. If flow meter output is not visually available you may obtain flow rate through measurements and stopwatch. The UP and DOWN arrow keys may be used to change each digit. Press the ENTER key after each digit has been entered to advance to the next digit or the MENU key to back up.

```
      PUMP FLOW
FLOW : 004.80gpm
```



**The calibration routine may be exited at any time prior to pressing ENTER after the last digit has been entered by pressing the MENU key (several times) to back out. If there is a problem with flow units or flow meter calibration back out before completing MPC VECTOR calibration and fix the problem.**

- Once all digits have been entered and the ENTER key is pressed, the WET flow calibration routine is complete and you should see the following screen.

```
      PUMP FLOW
CALIBRATED
```



**After the ENTER key has been pressed it will take several seconds for the calibration routine to complete.**

- Pump flow calibration is complete.
- Press the MENU key three times to exit back to the main operating screen.

## 8.1.2 DRY Flow Calibration

The DRY Flow Calibration routine does not require the pump to run. Instead, the user may input known flow meter feedback values. This process can be used for fine adjustment of flow rate display, or in situations where it is not possible or not safe to run the pump during calibration.



The DRY Flow Calibration Routine may be used to make small adjustments to the MPC VECTOR calibration to ensure to make the MPC VECTOR display more closely matches the Flow Meter display.



If you are *not* using a flow meter for feedback, the DRY flow calibration routine can be used, but will display motor RPM instead of mA value during the procedure.

1. Press the MENU key to access the Calibration Menu.

```
  - M E N U -  
C A L I B R A T I O N
```

2. Press the ENTER key to access Pump Flow Calibration screen.

```
C A L I B R A T I O N  
P U M P   F L O W
```

3. Press the ENTER key to access Wet Pump Flow Calibration screen.

```
P U M P   F L O W  
W E T   C A L
```

4. Press the UP or DOWN key to access DRY Pump Flow Calibration screen.

```
P U M P   F L O W  
D R Y   C A L
```

5. Press the ENTER key to access the DRY Pump Flow Calibration routine. A blinking cursor will show you that you are adjusting the Current (mA).

```
  M I N   S E T P T   0 . 0 M A  
  F L O W :           0 . 0 0 G P M
```

6. Press the UP and/or DOWN keys to adjust the Current setpoint.

```
  M I N   S E T P T   4 . 0 M A  
  F L O W :           0 . 0 0 G P M
```

7. Press the ENTER key to accept this setpoint. The Cursor will now blink on the second line, indicating that the Flow is the active field. Press the UP and/or DOWN keys to adjust the Flow setpoint.

```
  M I N   S E T P T   4 . 0 M A  
  F L O W :           0 . 0 0 G P M
```

8. Press the ENTER key to access the MAX setpoint values. The cursor will blink on the top line indicating that the Current setpoint may be adjusted.

```
  M A X   S E T P T  1 6 . 0 M A  
  F L O W :           4 . 0 0 G P M
```

9. Press the UP and/or DOWN arrow keys to adjust the Max Current setpoint.

```
MAX SETPT 20.0MA  
FLOW :      4.00GPM
```

10. Press ENTER to accept the Current Setpoint. The cursor will blink on the bottom line indicating that the Flow setpoint may be adjusted.
11. Press the UP and/or DOWN arrow keys to adjust the Max Flow setpoint. Note that you can not set this value greater than the Maximum Flow the pump is rated for (you may see the maximum rated flow in the Pump Information screens).

```
MAX SETPT 20.0MA  
FLOW :      5.92GPM
```



**You may back out of the DRY calibration routine at any point up to now without saving any calibration settings. Use the MENU button to back up.**

12. Press the ENTER key to save the new Analog Calibration values. Upon completion of Calibration you should see the following screen.

```
PUMP FLOW  
CALIBRATED
```

13. Press the MENU key several times to return to Operations Mode.



**To optimize feedback, it is best to set 4mA to 0 flow and 20mA to a value slightly higher (10-20% or so) than your max desired flow setting. This allows the user a full range of flow setpoints as well as giving the MPC VECTOR the best possible Analog resolution.**

## 8.2 Analog Input Calibration

If you are not using the 4-20mA input to the MPC VECTOR for control, skip this section. To calibrate the Input Current you must first correctly wire an external signal source. Refer to *Section 5 – Installation: Low Voltage Input Connections, Analog Input*. As with the flow calibration routine, the Analog Input may be calibrated WET or DRY. To perform a WET calibration, the signal-generating device must be active and capable of generating the full range (low to high) of potential input signals. A DRY calibration requires no input signal.

If the MPC VECTOR is configured for Speed Control instead of Flow Control the displays below reflecting pump flow will be replaced with pump speed displays. For example the bottom line of step 8 of the WET Calibration routine will display ‘SPEED XXXX RPM’.

### 8.2.1 “WET” Analog Input Calibration (with a field signal)

1. The starting display will be:

```
SETPT      XX . XXX
FLOW       XX . XXX
```

2. Press the MENU key

```
– MENU –
CALIBRATION
```

3. Press the ENTER key

```
CALIBRATION
PUMP FLOW
```

4. Press the UP arrow key twice, to access the analog input calibration

```
CALIBRATION
ANALOG INPUT
```

5. Press the ENTER key

```
ANALOG INPUT
WET CAL
```

6. Press the ENTER key

```
APPLY MIN MA
ENTER TO START
```

7. Apply your desired minimum mA control signal to the MPC VECTOR (usually 4 mA)

8. Press the ENTER key

```
MIN SETPT  4 . 2 MA
FLOW       0 . 0 0 GPM
```

(The mA value will be equal to your input signal level)

(The lower line shows the setting the MPC VECTOR will use for this signal value)

9. Press the UP and DOWN arrow keys to change the Speed/Flow corresponding to the Analog Input Value.

10. Press the ENTER key once more to accept the calibration value

```
APPLY MAX MA
ENTER TO START
```

11. Apply your desired maximum mA control signal to the MPC VECTOR (usually 20 mA)

12. Press the ENTER key

```
MAX SETPT 20.2MA
FLOW      7.01GPM
```

(The mA value will be equal to your input signal level)

(The lower line shows the setting the MPC VECTOR will use for this signal value)

13. Press the UP and DOWN arrows to adjust the Speed/Flow corresponding to the Analog Input value.

14. Press the ENTER key once more to accept the calibration value

```
ANALOG INPUT
CALIBRATED
```

15. Analog input signal calibration is complete

16. Press the MENU key three times to exit back to the main operating screen.

If you receive the following message:

```
CURRENT DELTA
OUT OF RANGE
```

This indicates that there is not a wide enough range between your maximum and minimum analog signals. The minimum signal range is 3 mA. The most likely source of this error is the user did not change the value of the incoming analog signal when moving from the MIN calibration to the MAX calibration.

The analog input signal calibration procedure should be performed again, ensuring that a minimum of 3 mA difference exists between the MIN and MAX signal levels.

## 8.2.2 “DRY” Analog Input Calibration (keypad only, no signal present)

1. The starting display will be:

```
SETPT      XX.XXX
FLOW       XX.XXX
```

2. Press the MENU key

```
-MENU-
CALIBRATION
```

3. Press the ENTER key

```
CALIBRATION
PUMP FLOW
```

4. Press the UP arrow key twice, to access the analog input calibration

```
CALIBRATION
ANALOG INPUT
```

5. Press the ENTER key

```
ANALOG INPUT
WET CAL
```

6. Press the UP or DOWN key

```
ANALOG INPUT
DRY CAL
```

7. Press the ENTER key to access the DRY Pump Flow Calibration routine for ANALOG Flow Meters. A blinking cursor will show you that you are adjusting the Current (mA).

```
MIN SETPT  0.0MA
FLOW:      0.00GPM
```

8. Press the UP and/or DOWN keys to adjust the Current setpoint.

```
MIN SETPT  4.0MA
FLOW:      0.00GPM
```

9. Press the ENTER key to accept this setpoint. The Cursor will now blink on the second line, indicating that the 4mA Flow is the active field. Press the UP and/or DOWN keys to adjust the Flow setpoint.

```
MIN SETPT  4.0MA
FLOW:      0.00GPM
```

10. Press the ENTER key to access the MAX setpoint values. The cursor will blink on the top line indicating that the Current setpoint may be adjusted.

```
MAX SETPT 16.0MA
FLOW:      4.00GPM
```

11. Press the UP and/or DOWN arrow keys to adjust the Max Current setpoint.

```
MAX  SETPT  20 . 0MA
FLOW :      4 . 00GPM
```

12. Press ENTER to accept the Current Setpoint. The cursor will blink on the bottom line indicating that the Flow setpoint may be adjusted.

13. Press the UP and/or DOWN arrow keys to adjust the Max Flow setpoint.

```
MAX  SETPT  20 . 0MA
FLOW :      5 . 92GPM
```



**You may back out of the DRY calibration routine at any point up to now without saving any calibration settings by pressing the MENU key several times.**

1. Press the ENTER key to save the new Analog Calibration values. Upon completion of Calibration you should see the following screen.

```
ANALOG INPUT
CALIBRATED
```

2. Press the MENU key several times to return to Operations Mode.

## 8.3 Analog Output Calibration

The analog output calibration routine maps the motor speed of the MPC VECTOR to a 4-20mA output signal. The output signal is NOT proportional to pump flow. If a 4-20mA signal representing flow is required it must be obtained by splitting the flow meter output signal.

1. The starting display will be:

```
SETPT      XX.XXX
FLOW       XX.XXX
```

2. Press the MENU key

```
-MENU-
CALIBRATION
```

3. Press the ENTER key

```
CALIBRATION
PUMP FLOW
```

4. Press the UP ARROW key to access the analog output calibration

```
CALIBRATED
ANALOG OUTPUT
```

5. Press the ENTER key

```
SET 0% SPEED TO
04.0 MA
```

6. Use the UP and DOWN arrow keys to adjust the output signal as required. The actual output signal will vary and can be monitored with a meter or your facility control system. The value displayed on the screen may not match the actual output signal and is for visual reference only.

7. Press the ENTER key once more to accept the calibration

```
SET 100% SPEED TO
20.0 MA
```

8. Use the UP and DOWN arrow keys to adjust as in step 6 above

9. Press the ENTER key once more to accept the calibration value

ANALOG OUTPUT  
CALIBRATED

10. Analog output signal calibration is complete

11. Press the MENU key three times to exit back to the main operating screen

If you receive the following message:

CURRENT DELTA  
OUT OF RANGE

This indicates that the output current for 0% speed has been set greater than or equal to the output current setting for 100% speed. Repeat the process and ensure that the 0% calibrated signal is set to a value lower than the 100% calibrated signal.

## 8.4 PulsaGuard Pump Protection

PulsaGuard is designed to turn your pump off when running in dangerous conditions. These conditions are user configurable and can be easily modified to meet each application.

When flow meter feedback is being provided, PulsaGuard will turn off your motor if a low flow set point is crossed for more than 10 seconds. This will protect the pump in under-loaded or overloaded conditions, which would cause the flow to fall below the user's acceptable limit. The MPC VECTOR will also trigger an alarm condition if the flow set point cannot be reached for some reason. This alarm will be displayed on the MPC VECTOR display but will not shut the motor off. If the MPC VECTOR is operating without flow meter feedback PulsaGuard can read the motor current and shut off the pump if the current drops below the shut off level and stays under that level for 10 seconds, effectively protecting equipment from under-loaded conditions.

The PulsaGuard pump protection may be enabled and disabled as desired from the System Setup menus (see section 8.4.2: PulsaGuard Enable/Disable). Note that once a calibration is performed the pump protection is automatically enabled, you will not have to manually enable it.

### 8.4.1 PulsaGuard Calibrations, using Flow Meter Feedback

1. The starting display will be:

```
SETPT      XX.XXX
FLOW       XX.XXX
```

2. Press the MENU key

```
-MENU-
CALIBRATION
```

3. Press the ENTER key

```
CALIBRATION
PUMP FLOW
```

4. Press the UP key

```
CALIBRATION
PULSAGUARD
```

5. Press the ENTER key

```
MIN SETPOINT
SETPT:    0.00GPM
```

6. Using the UP and DOWN arrow keys set the low flow setpoint

```
MIN SETPOINT
SETPT:    0.50GPM
```

7. Press the ENTER key to complete the PulsaGuard Calibration.

PULSAGUARD  
CALIBRATED

## 8.4.2 PulsaGuard Calibrations, no Flow Meter Feedback

PulsaGuard may be calibrated WET or DRY. A WET calibration requires that the user simulate underloaded conditions.

Follow Steps 1-4 above. You should see the following screen

CALIBRATION  
PULSAGUARD

5. Press the ENTER key.

PULSAGUARD  
WET CAL

### WET CALIBRATION:

6. Press the ENTER key again to access the WET calibration routine.

START MOTOR  
YES=ENTR NO=MENU

7. Run the pump to meet desired low setpoint conditions. You may adjust the speed of the motor using the UP and DOWN arrow keys. The output current of the motor will be displayed on the screen. The values below are not indicative of what your display will show.

MIN SETPT 2.0A  
SPEED: 1200RPM

8. Once the MPC MPC VECTOR has reached the desired low current setpoint, press the ENTER key.

PULSAGUARD  
CALIBRATED

9. PulsaGuard Pump Protection is now calibrated and enabled.

### DRY CALIBRATION:

6. Press the UP key

PULSAGUARD  
DRY CAL

7. Press the ENTER key

```
MIN SETPOINT
SETPT :      0.0A
```

8. Use the UP and DOWN keys to adjust the current setpoint

```
MIN SETPOINT
SETPT :      2.0A
```

9. Press the ENTER key to accept the calibration value.

```
PULSAGUARD
CALIBRATED
```

10. PulaGuard Pump Protection is now calibrated and enabled.

## 8.5 Display Contrast Adjustment

Should adjustment of the contrast level of the display become necessary, use the following procedure while in the normal operating mode.

To increase contrast, press and hold



at the same time.

To decrease contrast, press and hold



at the same time.

## 8.6 Tuning the Control Algorithm



This option should only be used by control systems engineers who are familiar with tuning PID loops. This is not intended for the casual user. Changing these values may result in the system oscillating without settling on the set point or never reaching the set point at all. See *Section 21, Appendix 2* for more information and theory on PID control.

The MPC VECTOR allows users to tune the motor control algorithm to speed up or slow down the MPC VECTOR response time. This is done by adjusting the PID Controller parameter coefficients.

The user may adjust the Proportional coefficient,  $k_p$ , the Integration coefficient,  $k_i$ , and the Derivative coefficient,  $k_d$ , independently. The user may also view and modify the sampling period of the control loop,  $t_s$ .

### Modifying the PID coefficients

1. The starting display will be:

```
SETPT      XX.XXX  
FLOW      XX.XXX
```

2. Press the MENU key

```
  - MENU -  
CALIBRATION
```

3. Press the UP arrow key

```
  - MENU -  
SYSTEM SETUP
```

4. Press the ENTER key

```
SYSTEM SETUP  
STATUS
```

5. Press the DOWN

```
SYSTEM SETUP  
PID PARAMETERS
```

6. Press the ENTER key

```
PID PARAMETERS  
COEFFICIENTS
```

7. Press the ENTER key

```
PROPORTIONAL  
X.XXX
```

8. Press the UP and/or DOWN keys to adjust the denominator,  $k_p'$

PROPORTIONAL

X . 1 0 0

9. Press the ENTER key

INTEGRAL

X . XXX

10. Press the UP and/or DOWN keys to adjust the denominator,  $k_i'$

INTEGRAL

X . 0 5 0

11. Press the ENTER key

DERIVATIVE

X . XXX

12. Press the UP and/or DOWN keys to adjust the denominator,  $k_d'$

DERIVATIVE

X . 0 5 0

13. You may back out without saving the new PID coefficients at this point by hitting the MENU key several times to return to the first screen. If you want to save the changes press the ENTER key

P I D P A R A M E T E R S

C O E F F I C I E N T S

14. The new PID coefficients have been set.

## Modifying the Sampling Interval, when Flow Meter feedback is used

1. The starting display will be:

```
SETPT      XX.XXX  
FLOW      XX.XXX
```

2. Press the MENU key

```
- MENU -  
CALIBRATION
```

3. Press the UP arrow key

```
- MENU -  
SYSTEM SETUP
```

4. Press the ENTER key

```
SYSTEM SETUP  
STATUS
```

5. Press the DOWN key until you get to the PID screen

```
SYSTEM SETUP  
PID PARAMETERS
```

6. Press the ENTER key

```
PID PARAMETERS  
COEFFICIENTS
```

7. Press the UP arrow key

```
PID PARAMETERS  
SAMPLING PERIOD
```

8. Press the ENTER key

```
SAMPLING PERIOD  
PERIOD :      XXXMS
```

9. Press the UP and/or DOWN arrows to adjust the sampling period,  $t_s$

```
SAMPLING PERIOD  
PERIOD :      XXXMS
```

10. Press the ENTER key to accept the new sampling period

```
PID PARAMETERS  
SAMPLING PERIOD
```

11. The new PID sampling period has been set.

## 9. Flow Meter Input

The MPC VECTOR accepts flow meter process feedback from an analog (4-20mA) flow metering device. The manufacturer of the flow meter is not important but the process signal must conform to a set of minimum specifications in order to work with the MPC VECTOR.

### 9.1 Flow Meter Installation

Prior to installation make sure your flow meter conforms to the MPC VECTOR's flow meter specifications (refer to *Section 13, Specifications*). Your flow meter must also be calibrated independently prior to installation.

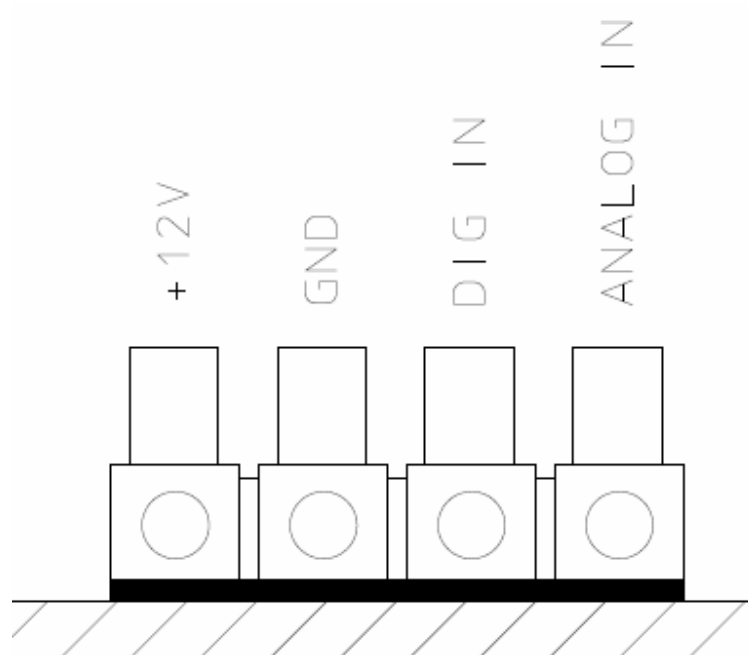

Figure 5 – Flow Meter Connection

1. Remove MPC VECTOR power and wait 30 seconds for complete power dissipation.
2. Connect your flow meter input to the Flow Meter Input Terminal Block (ref Fig. X.XX).
3. Plug in MPC VECTOR. After the system information is displayed the starting display will be:

```
SETPT      XX . XXX
FLOW       XX . XXX
```

4. Press the MENU key

```
- MENU -
CALIBRATION
```

5. Press the UP arrow key

```
- MENU -
SYSTEM SETUP
```

6. Press the ENTER key

```
SYSTEM SETUP
STATUS
```

7. Press the DOWN key five (5) times

```
SYSTEM SETUP
FLOW SENSOR
```

8. Press the ENTER key to enter the Flow Sensor setup menus.

```
FLOW SENSOR
SENSOR TYPE
```

9. Press the ENTER key to see the current sensor configuration.

```
SENSOR TYPE
INACTIVE
```

10. Press the ENTER key to change the sensor type.

```
SENSOR TYPE
<INACTIVE>
```

11. Press the UP arrow key until the analog flow meter option is displayed.

```
SENSOR TYPE
<ANALOG>
```

12. Press the ENTER key to accept the new configuration.

```
SENSOR TYPE
ANALOG
```

13. Press the MENU key several times to return to the Main screen.

14. Perform either a WET or DRY Flow Calibration on your MPC VECTOR (see *Section 8.1: Pump Flow Calibration*).

15. Your MPC MPC VECTOR is now ready for use with your flow meter.

# 10. Motor Parameter Setup and Tuning

The MPC VECTOR controller must know several motor characteristics before the motor can be calibrated. This calibration allows the controller to maintain precise control over the operation of the motor.

If the drive has not been calibrated an error will appear on the screen. In addition, at startup the User Interface will be redirected to the Calibration/Motor Parameter sub-menu.



**If your MPC VECTOR unit has been shipped from the factory as a complete unit with Eclipse pump and motor, these parameters will have been entered at the factory. No further user input will be required.**

Note that the ranges listed in the table below reflect absolute min/max accepted by the drive and may not match a specific application. These do not have to be set in any particular order but will be presented sequentially by the User Interface. The parameters will need to be entered in the field if the MPC VECTOR controller was shipped without a motor, or if the motor is changed to a different model than was originally supplied.



**SETTING THESE PARAMETERS IMPROPERLY AND RUNNING THE AUTO-CALIBRATION ROUTINE CAN RESULT IN DRIVE ERRORS.**

*Reference motor parameter table, next page*

Param.	Name	Description	Range	Typical	Note
85	Motor Rated Speed	Nameplate RPM Rating	300 – 65,000 RPM	1800 RPM	
86	Motor Rated Amps	Nameplate FLA Rating	0.0 – 480 Amps	Various	1
87	Motor Rated Volts	Nameplate Voltage Rating	0 – 600 Volts	230 VAC	
88	Motor Base Frequency	Nameplate Frequency	25 – 500 Hz	50 or 60 Hz	
91	Motor Cosine Phi	Nameplate Cosine Phi	0.4 – 0.99	Approx 0.8	2
81	Invoking this parameter begins the auto-calibration routine				

NOTES:

1. FLA = Full Load Amps
2. The Cosine Phi is also known as the **Power Factor**, this will sometimes be on the nameplate as “**PF**”. If the Power Factor is given as a %, always use the decimal equivalent (for example a power factor of 84% would be entered as 0.84) If the Cosine Phi is not provided by the motor manufacturer, one of the following formulas may be used.

$$(1) \text{COS } \Phi = \cos \left[ \sin^{-1} \left( \frac{\text{Magnetizing Current}}{\text{Motor Current}} \right) \right]$$

$$(2) \text{COS } \Phi = \frac{\text{Motor HP} \times 746}{\text{Motor Efficiency} \times \text{Motor Voltage} \times \text{Motor Current} \times 1.732}$$

After all of the Parameters have been entered, the drive needs to perform an auto-calibration routine (Parameter 81). This calibration routine will take several seconds to complete. The user may use the Menu Key to back up and/or out of the calibration any time prior to the auto calibration. The motor, and therefore the pump, will **not** run during this auto-calibration procedure.

## Setup Process

1. Navigate to the CALIBRATION menu, and scroll to the MOTOR PARAM option. The starting display will be:

```
CALIBRATION
MOTOR PARAM
```

2. Press the ENTER key

```
85
<1800>
```

3. Use UP and DOWN arrows to adjust value as required, then press the ENTER key

```
86
<1.2>
```

4. Use UP and DOWN arrows to adjust value as required, then press the ENTER key

```
87
<230>
```

5. Use UP and DOWN arrows to adjust value as required, then press the ENTER key

```
88
<60>
```

6. Use UP and DOWN arrows to adjust value as required, then press the ENTER key

```
91
<0.80>
```

7. Use UP and DOWN arrows to adjust value as required, then press the ENTER key

```
81
ENTER TO START
```

8. Press the ENTER key

```
CALIBRATING
```

9. The last screen will show

```
MOTOR PARAM
calibrated
```

10. Upon completion of the routine, remove power from the MPC VECTOR controller for one minute, and then re-apply power to complete the process.

After all of the Parameters have been entered, the drive needs to perform an auto-calibration routine (Parameter 81). This calibration routine will take several seconds to complete. The user may use the Menu Key to back up and/or out of the calibration any time prior to the auto calibration. The motor, and therefore the pump, will *not* run during this auto-calibration procedure.

# 11. Alarm and Error Messages

If a fatal error has occurred while in Operational Mode, the error will flash on the screen and the Red LED lamp will also flash. The menus can still be accessed by pressing the menu key. This allows the user to try and fix the source of the error if possible.

## 11.1 Error Log

As each error occurs an entry is saved in an Error Log. You may view the four most recent errors as well as the current status through the System Setup Menus.

### 11.1.1 Viewing the Error Log

1. The starting display will be:

```
SETPT      XX . XXX
FLOW       XX . XXX
```

2. Press the MENU key

```
  - MENU -
CALIBRATION
```

3. Press the UP arrow key

```
  - MENU -
SYSTEM SETUP
```

4. Press the ENTER key

```
SYSTEM SETUP
STATUS
```

5. Press the ENTER key again to view the current status

```
-- NO --
-- ERROR --
```

6. Press the DOWN key to view the most recent system error

```
ALARM
LEAK DETECT
```

7. Continue pressing the DOWN key to scroll through the 4 most recent errors.

8. Press the MENU key at any time, while viewing either current status or Log entries, to exit the Error Log.



**Once you see 'NO ERROR' in the Error Log (the screens AFTER current status) there will be no errors in any of the subsequent positions. If the pump turns off for any reason check the Error Log to see any messages that were reported. Some errors may clear themselves from the screen, but the entry will still be in the Error Log.**

### 11.1.2 Clearing Error Log Entries

Any of the entries in the Error Log may be cleared while viewing by pressing the ENTER key. If the problem is recurring or still present it may not be clearable.

## 11.2 Error Messages

The following table gives an example of these messages and when you can expect them to be displayed.

Message	Displayed When:
<b>FATAL ERRORS:</b> The pump and controller will not run while one of these error conditions exists. The Red LED will blink and the error message will flash on the screen. Users can access the menu system by pressing the MENU key. The red LED and the message will cease when the error condition has been corrected.	
Analog Input #X Out of Range	The analog input is less than 2.4 mA or greater than 24 mA
ALARM LOW LEVEL	The level monitoring input has triggered
ALARM AC DRIVE FAULT	Internal fault
ALARM MOTOR ERROR	The MPC VECTOR has detected that the motor shaft is not rotating at the expected speed
COMMUNICATION ERROR	Communication error exists between the MPC VECTOR controller and the keypad/display module

Continues next page...

**NON-FATAL ERRORS:** The pump and controller can still be run while these conditions exist. The Red LED will flash and the error will flash on the screen. The Red LED and error message will cease once the error condition has been corrected.

SOFTWARE Fault Error = ####	Software related problem, record error number and consult factory
Hardware fault Error = ####	Hardware related problem, record error number and consult factory
CONSULT factory Error = ####	Unidentified error, record error number and consult factory

**USER NOTIFICATIONS:** These are errors in setup or calibration. They will display on the screen for several seconds. They can be corrected by properly completing the procedure involved.

Cannot access With motor on	User is trying to change a setting that cannot be changed while the pump is running
Current delta Out of range	Not enough difference between high and low signals during an analog input signal calibration (min 3 mA)
No remote Control	User is trying to activate the AUTO mode, but there is no remote input (mA signal or remote on/off) to the controller



**For unlisted or numbered error codes, consult the factory for assistance.**

# 12. Specifications

Operation mode: AC motor speed control with sensorless speed feedback  
 Flow control with Flow Meter feedback

Power Requirements	Recommended Minimum Wiring and Circuit Breaker							
	Single Phase 208/230 VAC				Three Phase 208/230 VAC			
	Actual Draw	Circuit Breaker	Wire Size	Wire Size	Actual Draw	Circuit Breaker	Wire Size	Wire Size
MPC VECTOR and 1.0 Hp motor	10.6 A	15 A	14 AWG	2.0 mm <sup>2</sup>	5.8 A	10 A	14 AWG	2.0 mm <sup>2</sup>
MPC VECTOR and 2.0 Hp motor	14.8 A	20 A	14 AWG	2.0 mm <sup>2</sup>	9.1 A	15 A	14 AWG	2.0 mm <sup>2</sup>
MPC VECTOR and 3.0 Hp motor	19.7 A	25 A	12 AWG	3.5 mm <sup>2</sup>	12.4 A	20 A	14 AWG	2.0 mm <sup>2</sup>
MPC VECTOR and 5.0 Hp motor	---	---	---	---	19.6 A	25 A	12 AWG	3.5 mm <sup>2</sup>

**NOTE: AC drive capacitors will cause in-rush current demand when power is first applied to the unit.**

Control Inputs	Wiring	Specification / Description
Analog In #1	J11 pins 4-6	4-20mA control signal Max current 30mA; Input resistance 200 Ohm Internally protected with resettable fuse Minimum signal accepted = 2.4 mA Maximum signal accepted = 24 mA
Analog Flow Meter Input	Flow Meter Terminal Block Pins 1,2,4	4-20mA flow meter feedback signal Max current 30mA; Input resistance 200 Ohm Internally protected with resettable fuse Minimum signal accepted = 2.4 mA Maximum signal accepted = 24 mA
Digital In #1	J11 pins 1-3	User to provide dry-contact input *
Digital In #2	J11 pins 2-3	User to provide dry-contact input *
		<b>Do not apply power, maximum 2K Ohm resistance to register as "active"</b>

\* Digital input functions:

1. Remote on/off control of pump
2. Level input from supply tank
3. Leak Detection with external device
4. Flow detection with external device

<b>Control Outputs</b>	<b>Wiring</b>	<b>Specification / Description</b>
<b>Analog Out #1</b>	J23 pins 5-6	4-20mA output for pump flow indication Max voltage out 12 Volts; Max current out 30mA; Max load resistance 300 Ohm Internally protected with resettable fuse
<b>Digital Out #1</b>	J23 pins 1-4	Transistor-based output, various functions *
<b>Digital Out #2</b>	J23 pins 2-4	Transistor-based output, various functions *
<b>Digital Out #3</b>	J23 pins 3-4	Transistor-based output, various functions *
		<b>All digital outputs maximum 40 VDC, maximum 500 mA</b> <b>NOTE: requires external power source</b>

\* Digital output functions:

1. Triggering an external relay due to a fault condition
2. Auto/Manual status
3. On/Off status
4. Leak Detected
5. Tank level status indication

Calibration: Controller includes an on board program for signal and flow calibration.

Input Voltage: 230 (208 – 240 acceptable range) VAC  
Note: factory configured only for correct input voltage range (specified at time of purchase)  
Single Phase or Three-Phase (Single-Phase not available for 5 hp)  
50 or 60 Hz.

Tolerance: Input voltage +/- 10% maximum  
Input frequency range 48 Hz to 62 Hz

Motor Req: Commercially available motor supplied by the manufacturer of the pump controller  
**See following page for further motor information**

Motor Distance: Maximum motor to controller distance is 100 feet (30.5 meters)  
For distances greater than 25 feet (7.6 meters) see motor information, next page  
Consult factory for distances greater than 100 feet (30.5 meters)

Keypad: Mounted to MPC VECTOR main enclosure, can be made remote from the enclosure

Display: Backlit 2 line extended temperature 16 character LCD

Enclosure: NEMA 4X and IP56 ratings

Altitude: 3300 Ft (1000 M) above sea level (derate 5% for each additional 3300 feet)

Humidity: 0-90% (non-condensing)

Temperature: 0° C (32° F) Minimum operating temperature  
40° C (104° F) Maximum operating temperature

Earth Leakage Current: Size Earth Leakage Circuit Breakers (ELCB) to a detection level of 30 mA or greater

# Motor Selection and Requirements

## General Specifications

All motors used with the MPC VECTOR controller must meet these minimum specifications:

- 230 VAC, 50 or 60 Hz 3-phase input power AC induction motor
- 1800 rpm (60 Hz) or 1500 rpm (50 Hz) synchronous speed
- Service Factor 1.05 or greater
- Class F Insulation (minimum)
- Refer to your equipment specifications and documentation for the correct frame size
- Motors may or may not need feet and/or a C-face mount depending on equipment

## Turndown Requirements

Motor turndown ratings are dependent on the application and intended use of the pump. Users should understand and take into account the following factors when considering motor selection:

- Application required turndown ratio
- Viscosity of pumped liquid
- Length of wiring between the MPC VECTOR controller and the pump (motor)

Liquid Viscosity	Application Required Turndown Range		
	4:1	10:1	20:1
Low, below 50 CPS	3:1 or 4:1	N/A (see note below)	Consult factory
High, above 50 CPS	3:1 or 4:1	10:1	Consult factory

NOTE: when pumping liquids with low viscosity, pump performance is greatly diminished at slow rotational speeds due to internal slip. Therefore, high speed turndown ratios are not expected in this type of application.

Cable Length	Minimum Required Motor Turndown Rating	
MPC VECTOR to motor <b>less</b> than 25 feet (7.6 meters)	Use ratings guidelines in chart above	
MPC VECTOR to motor <b>greater</b> than 25 feet (7.6 meters)	<b>4:1 or 10:1 turndown</b>	<b>20:1 turndown</b>
	Must use 10:1 inverter duty rated motor	Consult factory

NOTE: the maximum pump to controller distance is 100 feet (30.5 meters). If longer distances are required, please contact the factory. Line and load reactors can be utilized to allow operation over longer distances.

# 13. Model Identification

Position	Sample	Specifies	Options
1 and 2	EP		EP – MPC VECTOR
3	C	Enclosure Type	C – meets NEMA 4X specifications
4	B	Motor Hp Rating *	<p>A - Fractional to 1.0 Hp (.37 kW); Drive Input: 208-230 Volt</p> <p>B - 2 Hp (1.5 kW); Drive Input: 208-230 Volt</p> <p>C - 3 Hp (2.2 kW); Drive Input: 208-230 Volt</p> <p>D - 5 Hp (3.7 kW); Drive Input: 208-230 Volt (3-phase only)</p>
5	X	Language	<p>X – English (default)</p> <p>A - German</p> <p>B - French</p> <p>C - Spanish</p>

\* Reference specific motor selection requirements in *Section 12, Specifications*

# 14. Menu Maps

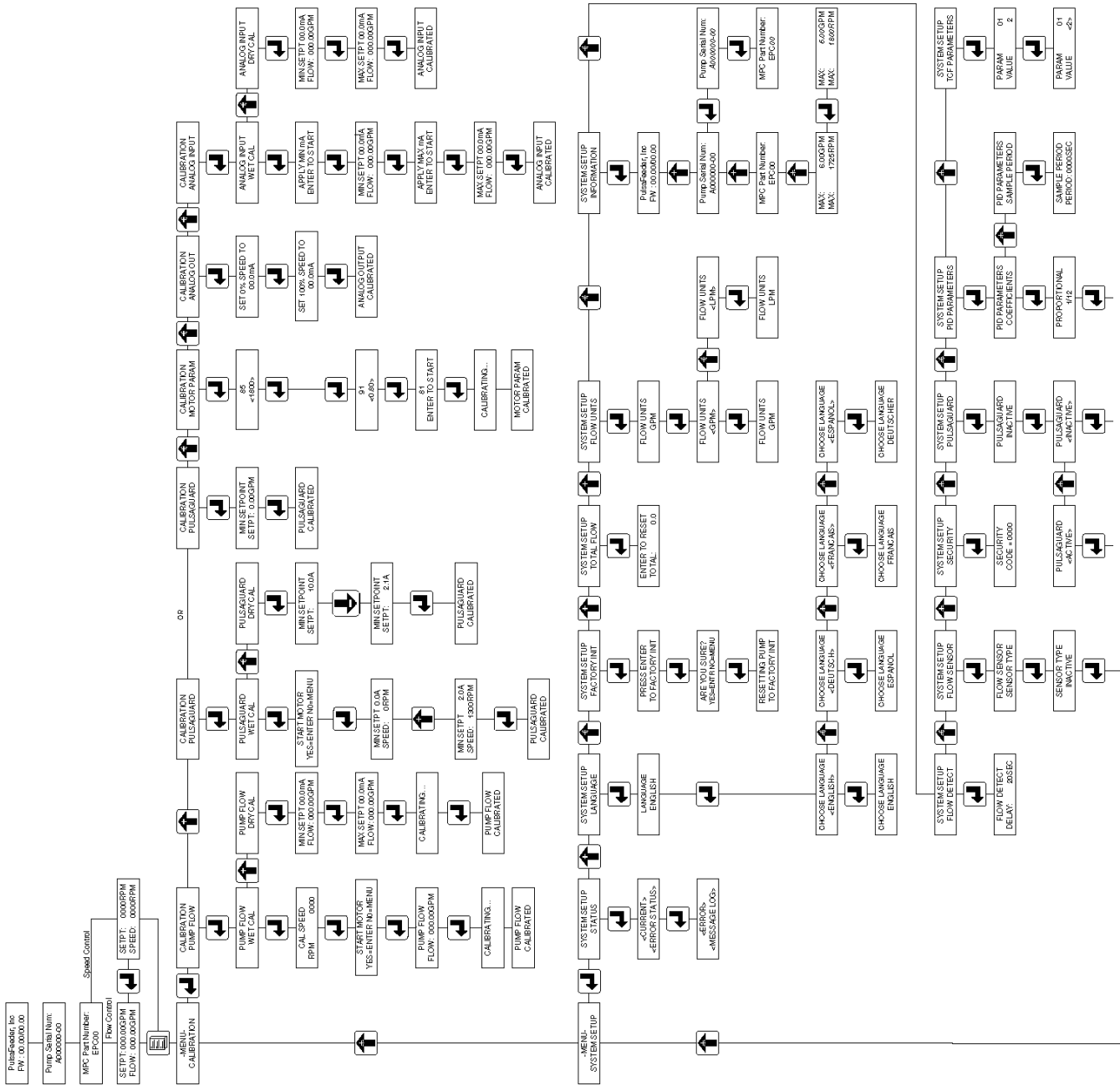

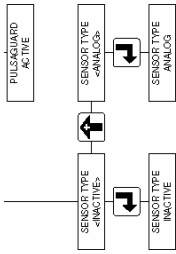
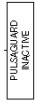
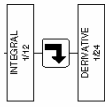



## 15. Factory Default Values

Parameter	Factory Set Value
Digital Input #1	INACTIVE, normally closed
Digital Input #2	INACTIVE, normally closed
Analog Input #1	INACTIVE
Analog Input #2	INACTIVE
Digital Output #1	ON/OFF indication, normally closed
Digital Output #2	AUTO/MANUAL Indication, normally closed
Digital Output #3	ALARM Indication, normally closed
Security Code	Default = 0000
Language	ENGLISH
MODE	Local (Manual)
UNITS	GPM (gallons per minute)

## 16. Retrieval of Setup Information

Users can access the system SETUP : INFORMATION menu, which will list the following data, this may be helpful in troubleshooting:

- Controller software revisions
- Pump serial number
- MPC VECTOR model number
- Pump maximum flow and PulsaGuard minimum flow setpoint
- Pump maximum speed and PulsaGuard minimum current setpoint

## 17. Special Key Press Access

In This SCREEN	Press MENU and ENTER at the same time to:
MENU ANALOG I/O	Show calibration and RAW data for analog inputs
MENU DIGITAL I/O	<i>Feature not available</i>

Press the MENU key to exit from any of these special screens.

# 18. Troubleshooting Guide

Problem	Potential Cause	Solution
---------	-----------------	----------

<b>DISPLAY</b>		
----------------	--	--

No Display Back-lighting	No power supplied.	Check power source. plug & circuit breaker
	Supply power wired incorrectly. Supply power outside of specification.	Check wiring. Check voltage/frequency against specification.
No Text on Display	Contrast out of adjustment.	Adjust as per section 8.4
	Software did not initiate properly.	Remove and re-apply AC power

<b>POWER</b>		
--------------	--	--

No power Indicators	No power supplied.	Check power source. Plug & Circuit Breaker
	Supply power wired incorrectly.	Check wiring.
	Supply power outside of specification.	Check voltage/frequency against specification.

# 19. Spare Parts

User replaceable parts for the MPC VECTOR.

Pulsafeeder P/N	Description
NP530091-000	½” wiring liquidtight connector
NP530137-000	¼” wiring liquidtight connector
W213946-NTR	Hand-held enclosure gasket
NP550113-000	Membrane keypad for hand-held
W772568-STL	½” conduit opening plug
W772585-018	¼” conduit opening plug

## 20. Appendix 1, Handheld Wiring

The hand-held controller for your MPC can be placed as far as 1000 feet from the main control unit. It is recommended that all calibrations be completed before the cable is lengthened, as these tasks are easier when the pump and hand-held controller are close to each other.



**POWER TO THE UNIT MUST BE OFF! A GROUNDING WRIST STRAP SHOULD BE WORN WHEN MAKING CONNECTIONS TO ANY PCB**

The following standard length cables are available from Pulsafeeder for use with the MPC:

Cable Length	Part Number	Notes
6 feet	NP530130-000	Standard, supplied with all MPC controllers
Others per foot	NP530147-000 (1 ft)	NOTE: do not exceed 1,000 feet total length

### 20.1 Removal and Connection of the Cable from the Handheld:

1. Open the handheld unit by removing the 4 screws on the face of the unit.
2. Open the unit by separating the cover from the base.
3. Use care with the keypad tail that is connected to the board, it can be left in place during this process.
4. Make a note of what color lead is in each position of the terminal block “J5”. Cut the tie-wrap that secures the cable. Unscrew each screw on the terminal block “J5” and remove each lead.
5. Loosen the outer domed nut on the liquid tight, releasing the tension on the cable. Pull the cable through the liquid tight. Thread the new cable through the liquid tight with enough length to reconnect to the terminal block.
6. Cut the shield wire as close as possible to the outer insulation at the remote end **only**.
7. Wrap the end of the cable with electrical tape to insulate any remaining shield so that it will not contact the circuit board, equipment case, or any other parts.
8. Referring to the notes taken earlier, connect each lead of the new cable to the proper position of the terminal block, lock the lever back in place to hold lead. NOTE: It is recommended that you insert and secure one lead at a time.
9. Tighten the dome nut of the liquid tight to secure/seal cable.
10. Check that the keypad tail is still firmly connected, re-insert if necessary.
11. Replace cover and tighten screws. Be sure the o-ring is in its groove, paying special attention to the corners. NOTE: Do not over tighten.

## 20.2 Removal and Connection of the Cable from the Base Unit:

**Wait a minimum of 5 minutes after disconnecting power before servicing the MPC or pump motor. Capacitors retain a charge even after power is removed from the controller.**

1. Remove the screws that are securing the cover of the main unit.
2. **CAUTION:** The cover is wired and should be opened gently being sure not to pull any of the wires that are connected to it.
3. Make a note of what color lead is in each position of the terminal block “J14”. Unscrew each screw on the terminal block “J14” and remove each lead.
4. Loosen the outer domed nut on the liquid tight, releasing the tension on the cable. Pull the cable through the liquid tight. Thread the new cable through the liquid tight with enough length to reconnect to the terminal block.
5. Prepare the end of the cable as per *figure 7* on the following page. Ensure that the shield is fully insulated until the point where it enters the terminal. No part of the shield should be allowed to come in contact with the circuit board, equipment case, or any other surface.
6. Note that the black-green lead should be paired with the green wire.
7. Referring to the notes taken earlier, connect each lead of the new cable to the proper position of the terminal block, and then lock the lever back in place to hold lead. **NOTE:** It is recommended that you insert and secure one lead at a time.
8. Tighten the dome nut of the liquid tight to secure/seal cable.
9. Replace cover carefully being sure not to crimp any of the cables/leads between cover and enclosure and tighten screws.
10. Power the unit on, if all connections were properly made the unit will power as normal and the display will show the start up screen.

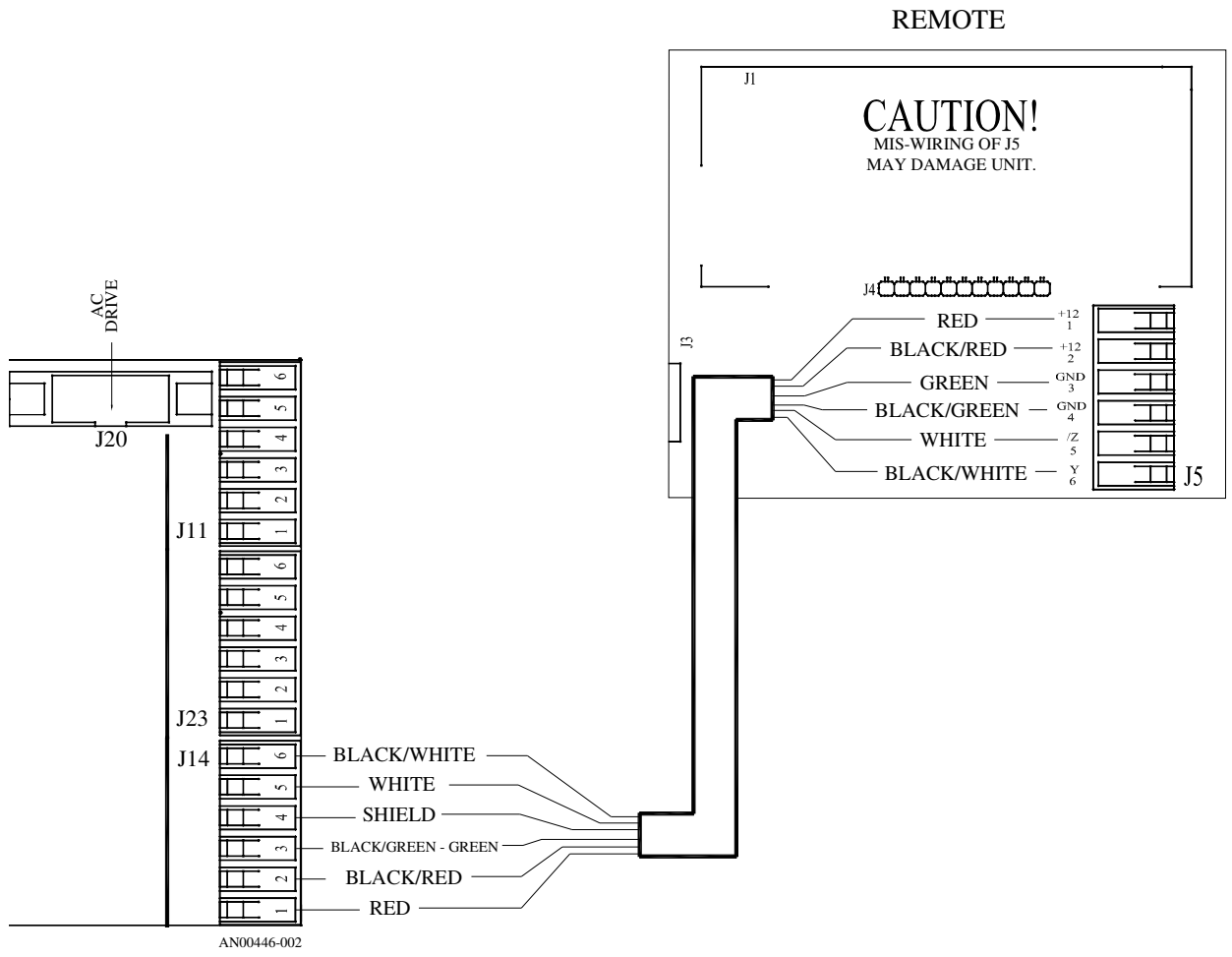

Figure 6 – Handheld Remote Wiring

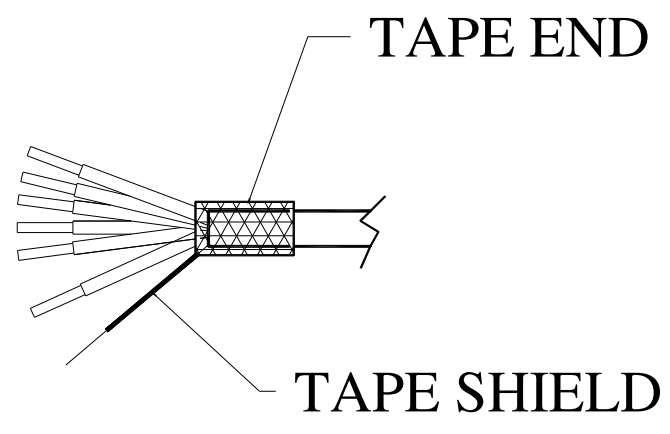
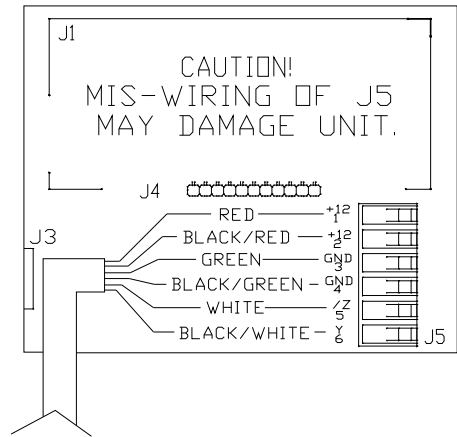
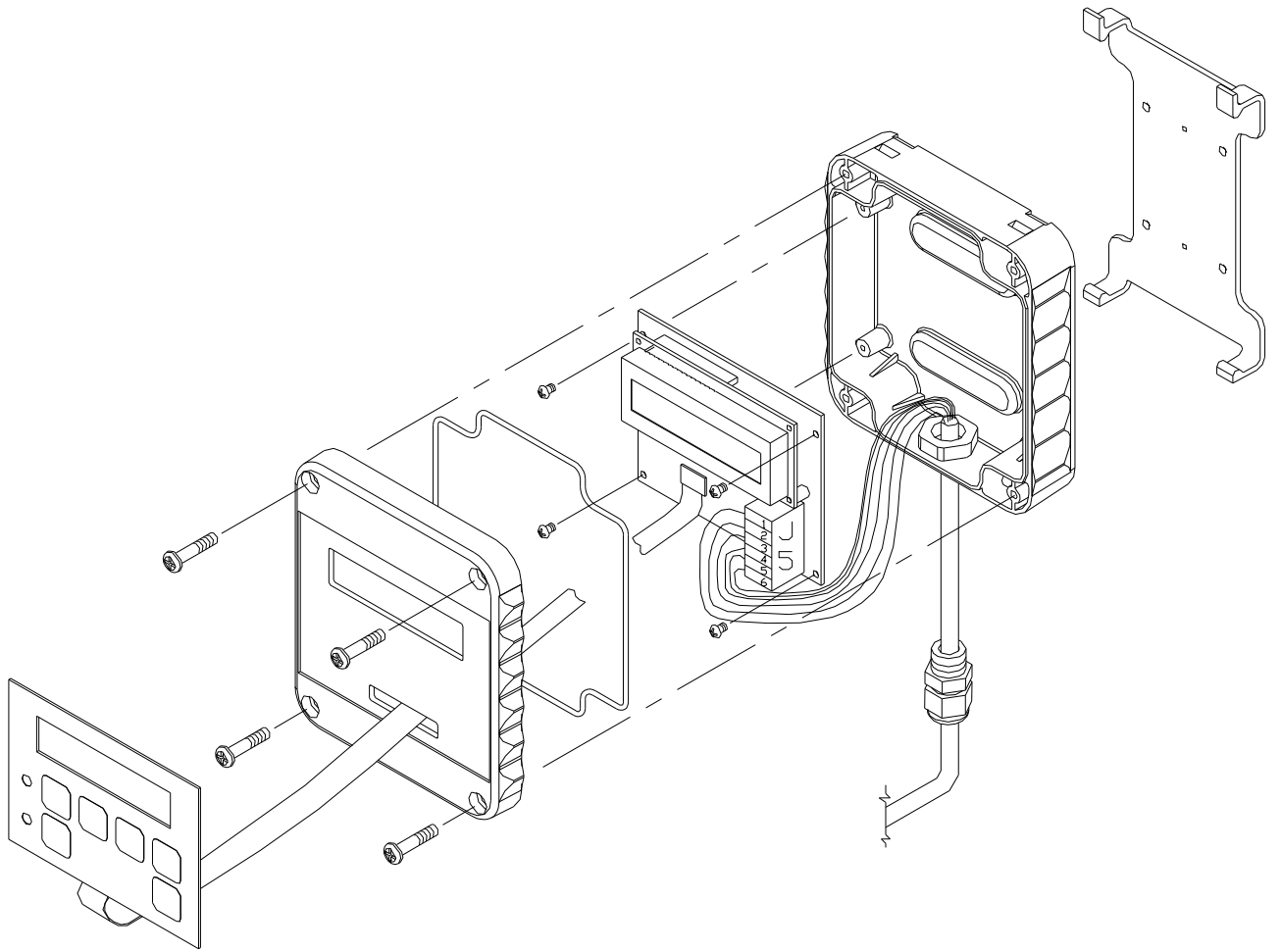

Figure 7 – Wire Preparation Detail, Base Unit End



WIRING DIAGRAM

AN0046-005

Figure 8 – Handheld Remote

## 21. *Appendix 2*, PID Theory and Adjustment

The PID control method allows the *MPC Vector* to accurately maintain a specific desired setpoint for flow rate from the pump it is connected to.

The PID Control Loop is a widely accepted general purpose control algorithm which is built into the *MPC Vector*. A PID control loop consists of three components which each have their own specific responsibilities in the control loop; the Proportional, Integral, and Derivative components. Although these mathematical terms are derived from calculus, and are internally implemented as such, the PID can be tuned without using a calculator by simply understanding the roles each of the three components play. Note that if you aren't interested in a semi-technical discussion of PID Control Loops you can skip ahead to *Section 21.3*.

### 21.1 PID Controller Theory:

The basic PID Control Loop consists of an input command, the control system, and feedback (*see diagram, following page*). The user enters an input flow rate. This command is sent through the control system which decides what the new motor speed should be. That motor speed command is sent to the pump which then changes the output rate. A flow meter at the output of the pump measures the output flow and feeds the data back to the controller. Based on the feed back the control system adjusts the motor speed and subsequently the flow in an attempt to meet the required set point. This process is repeated continuously bringing the flow rate closer and closer to the target until it eventually settles on the target. In the drawing, both the Requested Flow Rate and Control System are integrated into the MPC Vector controller.

## Basic MPC Vector Control Loop

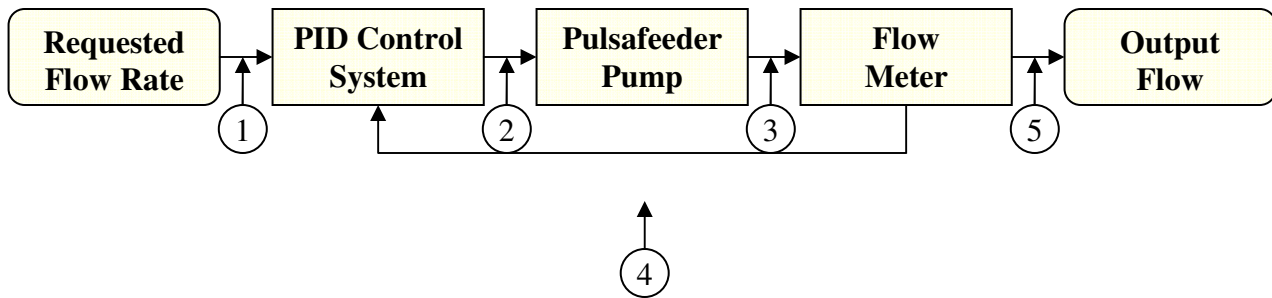

- ① Requested flow rate from the user
- ② Motor speed command from the control system
- ③ Flow output from the pump
- ④ Flow measurement from the flow meter
- ⑤ Flow output from flow meter

The function we are controlling is liquid flow from the pump, and the variable being controlled by the MPC Vector is motor speed. This control must be based on some type of feedback, in this case a flow meter measuring liquid flow rate.

### Feedback and Error

Feedback is critical in control systems. The feedback lets the controller know the actual flow rate being output by the pump at all times. Utilizing the feedback, the control system is able to determine the error which can be defined as the difference between the expected flow rate and the actual flow rate. The PID controller acts on the error, manipulating the process variable being controlled (in the case of the MPC Vector, motor speed) in order to bring the process closer to the setpoint, thereby eliminating the error.

The PID controller does not act on the actual flow rate being reported by the flow meter, it acts on the error between the actual flow rate, and the desired setpoint, it's goal being to eliminate the error between the two as much as possible.

### Sampling Rate

In the digital world the control loop is run at some base period which is called the sampling rate,  $T_s$ . After the initial command is given the control system waits for this period of time and then samples the output, compares it to the set point, and makes motor speed adjustments. After the same period of time expires again, it samples the flow rate again and compares it to the expected flow rate and adjusts. This continues as long as the pump is running. Like many other options for the MPC Vector, this is a configurable setting. The sampling rate of the MPC Vector should be at least twice as fast as the sampling rate of the flow sensor.

## 21.2 Three Control Components:

The PID controller has three adjustable internal components, all of which contribute to the final output value, they are proportional, integral, and derivative.

### Proportional Component

The proportional component of the control system (also known as “gain”) is concerned with the current error (“current” as in time, not electricity). The component is calculated by multiplying the current error by a proportional coefficient, commonly known as  $K_p$  or proportional gain. Since the proportional component is only concerned with current error it is able to contribute to initial startup speeds. Think of the proportional gain as the component which gives a jump start to the pump. Typical values of  $K_p$  for this application are in the 0.25 -> 0.7 range.

Proportional Part =  $K_p * \text{error}$

### Integral Component

The integral component of the control system (also known as “reset”) provides a historical memory to the system. This is accomplished by adding the errors into an error summation. The sum of the errors is then multiplied by an integral coefficient,  $K_i$  which is also called the integral gain. Because the integral component is a historical component, it can take some time to build “history”. The Integral component is used mainly to force the control to track closer to the desired setpoint, to eliminate any “offset”. Typical values of  $K_i$  are in the same range as  $K_p$ , 0.25 -> 0.7.

Integral Part =  $K_i * \text{error sum}$

### Derivative Component

The derivative component (also known as “rate”) provides a predictive element to the system. The derivative component compares the current error and previous error to calculate the approximate change over the last sample period. This is then multiplied by the differential coefficient,  $K_d$  which is also called the differential gain. When the flow rate of the pump is rising, the differential component is used to keep it from rising too fast. This is because as you get closer to the flow setpoint, the current error will be smaller than the last error. The differential term can be used to stabilize systems with excessive overshoot, it slows down the response as the setpoint is reached.

Derivative Part =  $K_d * (\text{error} - \text{last error})$

## 21.3 PID Basic Summary, what happens when I...

When the **proportional control** is *increased*:

- Initial rise time to setpoint gets faster
- Overshoot once setpoint is reached tends to increase (gets worse)
- Steady-state error can be reduced but will never be eliminated
- Settling time (ability to hold setpoint) is not strongly affected

**Proportional** is used mainly to affect the initial startup of the system, how quickly it reaches the desired setpoint. Too much proportional control will result in overshoot and oscillation, and inability to hold a setpoint over time.

When the **integral control** is *increased*:

- Initial rise time to setpoint gets faster
- Overshoot once setpoint is reached tends to increase (gets worse)
- Steady state error is eliminated with the proper setting
- Settling time (ability to hold setpoint) is increased (gets worse)
- Transient response ( for example to an upset condition) may get worse

**Integral** is used mainly to tune the system to reach a certain setpoint, to eliminate any offset the might be present, for example the desired flow rate is 5.0 gph, but the system settles and runs at a consistent 5.2 gph. If too much integral control is used, the system can overshoot, not settle, and not react smoothly to transient (temporary) upset events.

When the **derivative control** is *increased*:

- Stability of the system is increased
- Rise time to setpoint is not significantly affected
- Overshoot is controlled and decreased with the proper setting
- Settling time is decreased and controlled with the proper setting
- Steady state operation is not affected significantly

**Derivative** is used to tune out oscillation of the system around the desired setpoint. Too much derivative control will result in a system that never reaches setpoint, reacts too slowly, or is unstable and will not hold setpoint.

**A properly tuned PID loop will:**

- Reach the desired setpoint in a reasonable amount of time
- Maintain operation at or very close to the setpoint with minimal oscillation
- React quickly to transient changes or upset conditions

## 21.4 Putting it all together to run the *MPC Vector*

The proportional, integral, and differential components are all added together into a command sum which is used to set the motor speed. The motor speed command does have software protection which prevents the motor speed from ever exceeding the max motor speed or from being negative and therefore if the command loop is unstable, no damage can be caused to the drive, motor, or pump. ***Please be aware though that the motor could reach maximum speed during tuning and all necessary system precautions should be taken.***

Also note that the differential part alone can not be used to start the motor since it depends on previous values. If the previous saved error matches the current error then the differential part will be 0 and therefore the differential part alone will not start the motor reliably. It is possible to eliminate one of the parts by setting the appropriate coefficient to 0 (i.e. if you want a PI only controller set Kd to 0 to eliminate the differential part). However the tuning steps below assume that all 3 parts will be used.

***Step 1*** – Configure the *MPC Vector* (reference earlier sections of this IOM for more detail)

1. Make sure that the chosen flow meter is hooked up to the proper location in the MPC Vector.
2. Flow units should be set appropriately in the menu
3. Max flow should be set to at least the max flow achievable by the pump at max speed.
4. Flow sensor type should be set appropriately (digital or analog)
5. Flow calibration should be performed to make sure the MPC Vector flow reading matches flow meter feedback.

***Step 2*** – Choosing the test setpoint

In order to tune the PID loop it is necessary to choose a test speed. For most purposes the test flow should be set to approximately 80 – 85% of the max flow. If the test point is too close to the maximum flow, you may not notice the overshoot. If the test point is too low you may have an unstable system at higher flow rates.

***Step 3*** – Tune the Proportional gain

1. Start with an integral gain of 0 and a derivative gain of 0. The proportional gain should be set to allow the motor to start reliably.
2. Set the motor to the test setpoint
3. Start with a proportional gain of 0.1
4. Make sure that the integral and differential gains are 0
5. At the main operations mode screen, attempt to start the pump. If the motor starts and settles at a low speed with minimal flow then the proportional gain is set. If not, increase the gain by 0.05 and try again. Continue until motor start condition is met reliably.

***Step 4*** – Tune the Integral gain

1. The Integral gain is what will ultimately pull the speed up to the desired setpoint. Note that because the Integral gain is based on a sum it takes some time for the Integral part to stabilize.
2. Make sure that the proportional gain is set as found above. differential gain is still 0
3. Start with an integral gain of 0.05
4. At the main operations mode screen, start the pump. You should see that the flow is now slowly building towards the setpoint. Increasing the integral gain will cause the buildup to occur faster. Keep adding 0.05 to the integral gain until you overshoot your setpoint. As an example, if your setpoint is 5 GPM, your gain might go to 5.1 GPM before falling down to 4.9 GPM or so and oscillate for a few seconds.

Once you see the oscillation, back the integral gain down by 0.05 – 0.1. Start the pump again and make sure that the flow rate does not overshoot the setpoint significantly.

Note: you may want to use a stopwatch to time how long it takes to get to 80% of the setpoint, especially if you are using the Pulsaguard pump protection. Pulsaguard will stop the pump if the minimum flow is not reached within the timeout limit. In any case the pump should be able to get to at least 90% of the given flow setpoint within 25 seconds.

#### ***Step 5 – Tune the derivative gain***

The derivative gain is not required under all circumstances. In many cases, a PI controller alone is sufficient to control the pump flow. If derivative gain is added, start with a low setting (0.05 or so) and keep adjusting in 0.05 increments until desired settling time is met.

## **21.5 Troubleshooting**

### ***My flow rate is never reached. How can I fix it?***

If the flow rate is never reached you have what is called an over-damped system. Try increasing the Integral gain to help pull the setpoint up higher. Also, make sure your flow rates and units match. If you are trying to set a flow higher than the pump can provide, you'll never reach it!

### ***My flow goes past the setpoint and back below again and oscillates a long time. How can I fix it?***

Some oscillation is natural in many PID controlled systems. To minimize it you need to decrease the Proportional and/or Integral gains to slow the system down a bit.





A Unit of IDEX Corporation

## EC Declaration of Conformity

**Manufacturer:**

Pulsafeeder, Inc.  
2883 Brighton Henrietta Townline Rd.  
Rochester, NY 14623 USA

Pulsafeeder Inc. declares the following product(s) comply with the applicable standard(s) as listed below:

**Device(s):**

Metering Pump Controller (MPC)

**Description:**

Servo Controllers for Metering Pumps

**Applicable EU Directive(s) for all MPC(s):**

73/23/EEC - Low Voltage (LVD)

**Applicable EU Directive(s) for only 230VAC Input MPC(s):**

89/336/EEC - Electromagnetic Compatibility (EMC)

**Applicable Harmonized Standard(s) for all MPC(s):**

EN61010-1:2001

**Applicable Harmonized Standard(s) for only 230VAC Input MPC(s):**

EN61000-4-3, EN61000-4-4, EN61000-4-5,  
EN61000-4-6, EN 61000-6-2, EN61000-6-4

DATE/APPROVAL/TITLE:

12 May 2004

A handwritten signature in black ink, appearing to read 'Nick Valente', written over a horizontal line.

Nick Valente, Vice President of Business Development



**BULLETIN No. IOM-MPCV-0206**  
**Rv J**



Engineered Pump Operations  
2883 Brighton-Henrietta Townline Road  
Rochester, New York 14623  
Telephone: (585) 292-8000 Fax: (585) 424-5619  
<http://www.pulsa.com> [pulsa@idexcorp.com](mailto:pulsa@idexcorp.com)

